

# BUYERS GUIDE 2019



**mares**



## Seventy wonderful years: driven by passion.

Ludovico Mares was the legend and founder of Mares diving. Ludovico's passion for diving created a spark of enthusiasm that has spread unchanged for 70 years, and generation to generation. For this reason, Mares is a leading company in the world of diving. Technology, quality, reliability and innovation: everything is inspired by passion. Passionate people allow us to achieve our ambitious goals and to set increasingly innovative objectives. Designing and creating state-of-the-art equipment, being the first to test innovations, and recognizing new things are secrets to our success. Everything we do aims to increase diving enjoyment through superior technology and advanced performance. **Working with passion is a great privilege.**

## It's time to give back.

As divers ourselves, we love and respect the underwater world, including everything in it. This is a fundamental and core element of our passion; but the seas and oceans ask us to do more. The time has come to act. We have adopted concrete measures to reduce unnecessary plastic in our company, and share the message with employees, collaborators and suppliers. To safeguard what we love most, we must do our part to preserve all bodies of water, especially for those who follow in our footsteps, including future generations. Oceans need to be plastic free. **This is our commitment, and why we are part of MISSION DEEP BLUE.**



[www.missiondeepblue.com](http://www.missiondeepblue.com)



REGULATORS	6
INSTRUMENTS	22
BCD'S	32
SUITS	42
FINS	62
MASKS & SNORKELS	74
ACCESSORIES	90
TECH FEATURES	111



BREATHING SYSTEMS	114
BUOYANCY SYSTEMS	122
INSULATION SYSTEMS	136
ACCESSORIES	144



FREEDIVING	158
COMPUTERS	166
FINS	170
MASKS & SNORKELS	180
NEOPRENE	188
PNEUMATIC GUNS	202
SLING GUNS	208
ACCESSORIES	214



FINS - ADULT / JUNIOR	238
MASKS & SNORKELS - ADULT / JUNIOR	246
COMBOS - ADULT / JUNIOR	258
SETS - ADULT / JUNIOR	272
NEOPRENE - ADULT / JUNIOR	276



REGULATORS	284
BCD'S	288
SUITS	290
FIN, MASK & SNORKELS	296
ACCESSORIES	300



304



**SCUBA DIVING**

**mares**

**EPIC ADJ 82X\*****NEW**code: **416247 - INT / DIN 300****1<sup>ST</sup> STAGE**

- PVD COATING
- SWIVEL TURRET
- NATURAL DFC ON ALL LP PORTS
- OPD - TILTED HP PORTS
- AST - 1<sup>ST</sup> STAGE DRY SYSTEM
- COMPACT DIMENSIONS

**2<sup>ND</sup> STAGE**

- METAL 2<sup>ND</sup> STAGE WITH PVD COATING
- TWIN POWER SYSTEM
- ADJUSTABLE BREATHING COMFORT
- PAD - PNEUMATICALLY ASSISTED DESIGN
- HIGH AIR FLOW
- WIDE PIVOTING PURGE BUTTON
- COLD WATER USE
- SUPERFLEX HOSE

**TECHNICAL FEATURES**

Weight (g)	INT	DIN 300
1 <sup>st</sup> stage	964	790
2 <sup>nd</sup> stage	329	
Total Weight (including hose)	1429	1255

**ACCESSORIES**

	code	page
Octopus Epic Adj	416550	16
DIN connector 82X	416809	18
CWD Kit 82X	416859	18
Twin Balanced Piston Dry Kit	416860	18

**DETAILS**

Swivel Turret - Natural DFC on all LP ports



AST - 1st stage Dry System (DIN version)

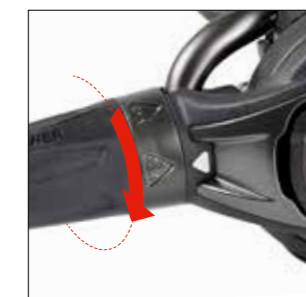

Twin Power System



Adjustable breathing comfort

# REGULATORS

Mares regulators have been tested and certified in compliance with EC directive 89/686/EEC and/or European Regulation 2016/425 according to the EN 250: 2014 standard and EN13949 (Nitrox regulators).

All Mares Nitrox regulators are compatible with oxygen mixes up to 100% O<sub>2</sub> and are equipped with a dedicated connection in conformity with European standard EN144-3.

\* Achieved EN250 work of breathing requirements at the depth of 200 m at a breathing rate of 62,5 l/min while using a breathing mix of 6,7% oxygen, 83,3% helium and 10% nitrogen. This gas mixture has a density at 200m equivalent to the density of air at 50m.

**ULTRA ADJ 82X\*****NEW**

code: 416250 - INT / DIN 300

- 1<sup>ST</sup> STAGE
- NATURAL DFC ON ALL LP PORTS
  - SWIVEL TURRET
  - OPD - TILTED HP PORTS
  - AST - 1<sup>ST</sup> STAGE DRY SYSTEM
  - PEARL CHROME FINISH
  - COMPACT DIMENSIONS
- 2<sup>ND</sup> STAGE
- TWIN POWER SYSTEM
  - ADJUSTABLE BREATHING COMFORT
  - PAD - PNEUMATICALLY ASSISTED DESIGN
  - HIGH AIR FLOW
  - ULTRALIGHT TECHNOLOGY
  - WIDE PIVOTING PURGE BUTTON
  - SUPERFLEX HOSE

**TECHNICAL FEATURES**

Weight (g)	INT	DIN 300
1 <sup>st</sup> stage	964	790
2 <sup>nd</sup> stage	192	
Total Weight (including hose)	1292	1118

**ACCESSORIES**

	code	page
Octopus Ultra Adj	416553	16
1 <sup>st</sup> stage 82X	416248	15
DIN connector 82X	416809	18
CWD Kit 82X	416859	18

**DETAILS**

Swivel Turret - Natural DFC on all LP ports

AST - 1st stage Dry System (DIN version)

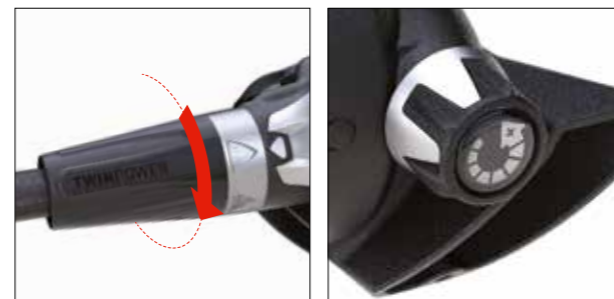

Twin Power System

Adjustable breathing comfort

\* Achieved EN250 work of breathing requirements at the depth of 200 m at a breathing rate of 62,5 l/min while using a breathing mix of 6,7% oxygen, 83,3% helium and 10% nitrogen. This gas mixture has a density at 200m equivalent to the density of air at 50m.

**ULTRA 72X\*****NEW**

code: 416251 - INT / DIN 300

- 1<sup>ST</sup> STAGE
- 4 VERTICAL AND 4 RADIAL LP PORTS (PAT. PENDING)
  - IDEAL FOR ALL TECH AND RECREATIONAL DIVING CONFIGURATIONS
  - NATURAL DFC ON ALL LP PORTS
  - PRE-ORIENTED HP PORTS
  - AST - 1<sup>ST</sup> STAGE DRY SYSTEM
  - PEARL CHROME FINISH
  - COMPACT DIMENSIONS
- 2<sup>ND</sup> STAGE
- TWIN POWER SYSTEM
  - HIGH AIR FLOW
  - ULTRALIGHT TECHNOLOGY
  - WIDE PIVOTING PURGE BUTTON
  - SUPERFLEX HOSE

**TECHNICAL FEATURES**

Weight (g)	INT	DIN 300
1 <sup>st</sup> stage	882	708
2 <sup>nd</sup> stage	190	
Total Weight (including hose)	1208	1034

**ACCESSORIES**

	code	page
Octopus Ultra	416554	16
1 <sup>st</sup> stage 72X	416256	15
DIN connector 82X	416809	18
Twin Balanced Piston Dry Kit	416860	18

**DETAILS**

Vertical and Radial Lp ports (Pat. Pending)

AST - 1st stage Dry System (INT version)



Twin Power System

Pivoting Purge Button

\* Achieved EN250 work of breathing requirements at the depth of 200 m at a breathing rate of 62,5 l/min while using a breathing mix of 6,7% oxygen, 83,3% helium and 10% nitrogen. This gas mixture has a density at 200m equivalent to the density of air at 50m.

**FUSION 72X\*****NEW**

code: 416252 - INT / DIN 300

- 1<sup>ST</sup> STAGE
- 4 VERTICAL AND 4 RADIAL LP PORTS (PAT. PENDING)
  - IDEAL FOR ALL TECH AND RECREATIONAL DIVING CONFIGURATIONS
  - NATURAL DFC ON ALL LP PORTS
  - PRE-ORIENTED HP PORTS
  - AST - 1<sup>ST</sup> STAGE DRY SYSTEM
  - PEARL CHROME FINISH
  - COMPACT DIMENSIONS

- 2<sup>ND</sup> STAGE
- TWIN POWER SYSTEM
  - METAL 2<sup>ND</sup> STAGE WITH PEARL CHROME FINISH
  - HIGH AIR FLOW
  - WIDE PIVOTING PURGE BUTTON
  - SUPERFLEX LP HOSE

**TECHNICAL FEATURES**

Weight (g)	INT	DIN 300
1 <sup>st</sup> stage	882	708
2 <sup>nd</sup> stage	327	
Total Weight (including hose)	1345	1171

**ACCESSORIES**

	code	page
Octopus Fusion	416544	16
1 <sup>st</sup> stage 72X	416256	15
DIN connector 52X	416809	18
Twin Balanced Piston Dry Kit	416860	18

**DETAILS**

Vertical and Radial Lp ports (Pat. Pending)



AST - 1st stage Dry System (INT version)



Twin Power System



Pivoting Purge Button

\* Achieved EN250 work of breathing requirements at the depth of 200 m at a breathing rate of 62,5 l/min while using a breathing mix of 6,7% oxygen, 83,3% helium and 10% nitrogen. This gas mixture has a density at 200m equivalent to the density of air at 50m.

**LOOP 72X****NEW**

code: 416253 - INT / DIN 300

- 1<sup>ST</sup> STAGE
- 4 VERTICAL AND 4 RADIAL LP PORTS (PAT. PENDING)
  - IDEAL FOR ALL TECH AND RECREATIONAL DIVING CONFIGURATIONS
  - NATURAL DFC ON ALL LP PORTS
  - AST - 1<sup>ST</sup> STAGE DRY SYSTEM
  - PEARL CHROME FINISH
  - PRE-ORIENTED HP PORTS
  - COMPACT DIMENSIONS

- 2<sup>ND</sup> STAGE\*
- "UNDER-THE-SHOULDER" HOSE POSITION
  - CAN BE MOUNTED ON THE RIGHT OR LEFT SIDE
  - FREEDOM OF MOVEMENT IN ALL DIRECTIONS
  - INTEGRATED SAGITTAL VAD (S-VAD)
  - TWIN EXHAUST VALVE
  - OVERSIZED SILICONE PURGE BUTTON

**TECHNICAL FEATURES**

Weight (g)	INT	DIN 300
1 <sup>st</sup> stage	882	708
2 <sup>nd</sup> stage	199	
Total Weight (including hose)	1256	1082

**ACCESSORIES**

	code	page
Octopus Loop	416548	16
1 <sup>st</sup> stage 72X	416256	15
DIN Connector 15X	416809	18
Twin Balanced Piston Dry Kit	416860	18

\* Pat pending

**ABYSS 22 NAVY II**

code: 416171 - INT / DIN 300

- 1<sup>ST</sup> STAGE
- HI FLOW DFC PORT
  - PRE-ORIENTED PORTS
  - INT - DIN CONNECTION
  - CWD OIL KIT
  - US NAVY APPROVED

- 2<sup>ND</sup> STAGE
- VAD SYSTEM
  - MESH GRID
  - FLUOROPOLYMER RESIN FINISH
  - RUBBER HOSE
  - IDEAL FOR EXTREME COLD WATER

**TECHNICAL FEATURES**

Weight (g)	INT	DIN 300 bar
1 <sup>st</sup> stage	850	685
2 <sup>nd</sup> stage	269	
Total Weight (including hose)	1337	1172

**ACCESSORIES**

	code	page
Octopus Abyss Navy	416546	16
Low pressure plug (1/2")	46186207	-

**DUAL ADJ 52X\*****NEW**

code: 416257 - INT / DIN 300

- 1<sup>ST</sup> STAGE
- DOUBLE DFC PORTS
  - PRE-ORIENTED LP AND HP PORTS
  - AST - 1<sup>ST</sup> STAGE DRY SYSTEM
  - PEARL CHROME FINISH
  - NCC TECHNOLOGY
- 2<sup>ND</sup> STAGE
- ADJUSTABLE BREATHING COMFORT
  - ULTRALIGHT TECHNOPOLYMER
  - PAD - PNEUMATICALLY ASSISTED DESIGN
  - HIGH AIR FLOW
  - LIGHTWEIGHT
  - OVERSIZED PURGE BUTTON
  - SUPERFLEX HOSE

**TECHNICAL FEATURES**

Weight (g)	INT	DIN 300
1 <sup>st</sup> stage	687	513
2 <sup>nd</sup> stage	185	
Total Weight (including hose)	1002	828

**ACCESSORIES**

	code	page
Octopus Dual Adj	416555	17
1 <sup>st</sup> stage 52X	416231	15
DIN Connector 52X	416809	18
CWD Dry Kit 52X	416857	18

**DETAILS**

AST - 1st stage Dry System



Technopolymer case with Integrated VAD



Adjustable breathing comfort



Bi-Material Purge Button

\* Achieved EN250 work of breathing requirements at the depth of 200 m at a breathing rate of 62,5 l/min while using a breathing mix of 6,7% oxygen, 83,3% helium and 10% nitrogen. This gas mixture has a density at 200m equivalent to the density of air at 50m.

**DUAL 15X****NEW**

code: 416258 - INT / DIN 300

- 1<sup>ST</sup> STAGE
- DFC PORT
  - PRE-ORIENTED PORTS
  - COMPACT SIZE
  - SANDBLASTED FINISH
- 2<sup>ND</sup> STAGE
- TECHNOPOLYMER
  - LIGHTWEIGHT
  - OVERSIZED PURGE BUTTON
  - HIGH AIR FLOW
  - SUPERFLEX HOSE

**TECHNICAL FEATURES**

Weight (g)	INT	DIN 300
1 <sup>st</sup> stage	772	598
2 <sup>nd</sup> stage	183	
Total Weight (including hose)	1085	911

**ACCESSORIES**

	code	page
Octopus Dual	416556	17
1 <sup>st</sup> stage 15X	416237	15
DIN Connector 15X	416809	18
CWD Dry Kit 15X	416857	18

\* Pat pending

**LOOP 15X**

code: 416241 - INT / DIN 300

- 1<sup>ST</sup> STAGE
- DFC PORT
  - PRE-ORIENTED PORTS
  - COMPACT SIZE
  - SANDBLASTED FINISH
- 2<sup>ND</sup> STAGE\*
- "UNDER-THE-SHOULDER" HOSE POSITION
  - CAN BE MOUNTED ON THE RIGHT OR LEFT SIDE
  - FREEDOM OF MOVEMENT IN ALL DIRECTIONS
  - INTEGRATED SAGITTAL VAD (S-VAD)
  - TWIN EXHAUST VALVE
  - OVERSIZED SILICONE PURGE BUTTON

**TECHNICAL FEATURES**

Weight (g)	INT	DIN 300
1 <sup>st</sup> stage	772	598
2 <sup>nd</sup> stage	199	
Total Weight (including hose)	1146	972

**ACCESSORIES**

	code	page
Octopus Loop	416548	16
1 <sup>st</sup> stage 15X	416237	15
DIN Connector 15X	416809	18
CWD Dry Kit 15X	416857	18



## ROVER 15X

code: 416236 - INT / DIN 300

- 1<sup>st</sup> STAGE
  - DFC PORT
  - PRE-ORIENTED PORTS
  - COMPACT SIZE
  - SANDBLASTED FINISH
- 2<sup>nd</sup> STAGE
  - VAD SYSTEM WITH FLUID DYNAMIC DEFLECTOR
  - MID-SIZE
  - MESH GRID
  - OVERSIZED PURGE BUTTON
  - RUBBER HOSE



### TECHNICAL FEATURES

Weight (g)	INT	DIN 300 bar
1 <sup>st</sup> stage	772	598
2 <sup>nd</sup> stage	200	
Total Weight (including hose)	1117	943

### ACCESSORIES

	code	page
Octopus Rover	416505	17
1 <sup>st</sup> stage 15X	416237	15
DIN Connector 15X	416809	18
CWD Dry Kit 15X	416857	18

## ROVER 2S

code: 416220 - INT / DIN 300

- 1<sup>st</sup> STAGE
  - LIGHTWEIGHT, STURDY AND COMPACT
  - PISTON CONTROL
  - DEDICATED PLACE FOR RFID CHIP
- 2<sup>nd</sup> STAGE
  - VAD SYSTEM WITH FLUID DYNAMIC DEFLECTOR
  - MID-SIZE
  - MESH GRID
  - RUBBER HOSE
  - OVERSIZED PURGE BUTTON



### TECHNICAL FEATURES

Weight (g)	INT	DIN 300 bar
1 <sup>st</sup> stage	608	432
2 <sup>nd</sup> stage	200	
Total Weight (including hose)	987	808

### ACCESSORIES

	code	page
Octopus Rover	416505	17
1 <sup>st</sup> stage 2S	416232	15
DIN Connector 2S	416809	18

## 82X

code: 416248 - INT / DIN 300

- SWIVEL TURRET
- NATURAL DFC ON ALL LP PORTS
- OPD - TILTED HP PORTS
- AST - 1<sup>st</sup> STAGE DRY SYSTEM
- COMPACT DIMENSIONS



### TECHNICAL FEATURES

Weight (g)	INT	DIN 300 bar
1 <sup>st</sup> stage	964	790

## 52X

code: 416231

- DOUBLE DFC PORTS
- PRE-ORIENTED LP AND HP PORTS
- PEARL CHROME FINISH
- NCC TECHNOLOGY



### TECHNICAL FEATURES

Weight (g)	INT	DIN 300 bar
1 <sup>st</sup> stage	687	513

## 2S

code: 416232

- LIGHTWEIGHT, STURDY AND COMPACT
- PISTON CONTROL
- DEDICATED PLACE FOR RFID CHIP



### TECHNICAL FEATURES

Weight (g)	INT	DIN 300 bar
1 <sup>st</sup> stage	608	432

## 72X

NEW

code: 416256

- 4 VERTICAL AND 4 RADIAL LP PORTS (PAT. PENDING)
- IDEAL FOR ALL TECH AND RECREATIONAL DIVING CONFIGURATIONS
- NATURAL DFC ON ALL LP PORTS
- AST - 1<sup>st</sup> STAGE DRY SYSTEM
- PEARL CHROME FINISH
- PRE-ORIENTED HP PORTS
- COMPACT DIMENSIONS



### TECHNICAL FEATURES

Weight (g)	INT	DIN 300 bar
1 <sup>st</sup> stage	882	708

## 15X

code: 416237

- DFC PORT
- PRE-ORIENTED PORTS
- SANDBLASTED FINISH



### TECHNICAL FEATURES

Weight (g)	INT	DIN 300 bar
1 <sup>st</sup> stage	772	598

\* For use with octopuses and 2nd stages with which it has been certified. The assembly, check and any necessary adjustments must be done by a Mares Lab Authorized Service Center.

**OCTOPUS EPIC ADJ****NEW**

code: 416550

- METAL 2<sup>ND</sup> STAGE WITH PVD COATING
- TWIN POWER SYSTEM
- ADJUSTABLE BREATHING COMFORT
- PAD - PNEUMATICALLY ASSISTED DESIGN
- HIGH AIR FLOW
- WIDE PIVOTING PURGE BUTTON
- COLD WATER USE
- SUPERFLEX HOSE

**OCTOPUS ULTRA ADJ****NEW**

code: 416553

- TWIN POWER SYSTEM
- ADJUSTABLE BREATHING COMFORT
- PAD - PNEUMATICALLY ASSISTED DESIGN
- HIGH AIR FLOW
- ULTRALIGHT TECHNOPOLYMER 2ND STAGE
- WIDE PIVOTING PURGE BUTTON
- SUPERFLEX HOSE

**OCTOPUS ULTRA****NEW**

code: 416554

- TWIN POWER SYSTEM
- TECHNOPOLYMER
- ULTRALIGHT
- OVERSIZED SILICONE PURGE BUTTON
- HIGH AIR FLOW
- SUPERFLEX HOSE

**OCTOPUS FUSION**

code: 416544

- TWIN POWER SYSTEM
- VAD SYSTEM
- HIGHEST AIR FLOW
- SUPERFLEX HOSE
- WIDE PIVOTING PURGE BUTTON

**OCTOPUS LOOP**

code: 416548

- CAN BE MOUNTED ON THE RIGHT OR THE LEFT SIDE
- FREEDOM OF MOVEMENT IN ALL DIRECTIONS
- "UNDER THE SHOULDER" HOSE POSITION
- TWIN EXHAUST VALVES
- INTEGRATED SAGITTAL VAD (S-VAD)
- OVERSIZED SILICONE PURGE BUTTON

**OCTOPUS ABYSS NAVY**

code: 416546

- VAD SYSTEM
- MESH GRID
- FLUOROPOLYMER RESIN FINISH
- RUBBER HOSE
- EXTREMELY COLD WATER USE

**OCTOPUS DUAL ADJ****NEW**

code: 416555

- ADJUSTABLE BREATHING COMFORT
- PAD - PNEUMATICALLY ASSISTED DESIGN
- HIGH AIR FLOW
- TECHNOPOLYMER
- ULTRALIGHT
- OVERSIZED PURGE BUTTON
- SUPERFLEX HOSE

**OCTOPUS DUAL****NEW**

code: 416556

- TECHNOPOLYMER
- LIGHTWEIGHT
- OVERSIZED PURGE BUTTON
- HIGH AIR FLOW
- SUPERFLEX HOSE

**OCTOPUS ROVER**

code: 416505

- VAD SYSTEM WITH FLUID DYNAMIC DEFLECTOR
- MID SIZED
- MESH GRID
- RUBBER HOSE
- OVERSIZED PURGE BUTTON

**AIR CONTROL\***

code: 416893

- COMBINED HOSE FOR OCTOPUS AND INFLATOR
- SPECIAL ADAPTORS TO FIT ALL BCDS
- ERGONOMIC SHAPE
- ONE-HANDED USE
- PRE-ORIENTED MOUTHPIECE
- MESH GRID COVER
- EASY TO PURGE, EVEN WITH THICK GLOVES
- SUPERFLEX HOSE



\* Available only in selected countries outside of the European Union

### 82X-72X-52X-15X-2S DIN CONNECTOR

code: **416809**

- FOR 200 AND 300 BAR USE
- CONICAL SINTERED FILTER



### AST DRY SYSTEM

code: **416811 INT**

code: **416812 DIN**

- AUTO-SEALING TECHNOLOGY
- KEEPS THE 1ST STAGE DRY
- ACTIVATED BY GAS
- CAN BE USED WITH A HIGHER PERCENTAGE OF OXYGEN
- CAN BE USED IN COLD WATER
- EASY TO INSTALL ON 82X-72X-52X-15X AND R2 1ST STAGES



### 82X CWD KIT

code: **416859**

- WITH SILICONE OIL, FOR EXTREME COLD WATER
- PROTECTS ALL MOVING PARTS
- EASY TO INSTALL



### 52X - 15X CWD DRY KIT

code: **416857**

- FOR COLD WATER USE
- PROTECTS ALL MOVING PARTS
- EASY TO INSTALL
- PLASTIC RING FOR 15X ONLY



### TWIN BALANCED PISTON DRY KIT **NEW**

code: **416860**

- FOR COLD WATER USE
- PROTECTS ALL MOVING PARTS
- EASY TO INSTALL



### SWIVEL

code: **415862**

- TO IMPROVE COMFORT
- 120 DEGREE ADAPTER
- EASY TO INSTALL BETWEEN HOSE AND 2ND STAGE
- 9/16" UNF



### DIN/YOKE ADAPTOR

code: **415861**

- FOR ALL DIN 1ST STAGES



### LIQUIDSKIN MOUTHPIECE

code: **415351** (6pcs unicolors)

- BI-SILICONE EXCLUSIVE TECHNOLOGY
- ORTHODONTICALLY OPTIMIZED
- EXTREMELY LOW JAW FATIGUE
- FITS ON ALL MARES REGULATORS



CL/BL

CL/YL

### JAX

code: 12 pcs mix **415336** (2 pcs BL/YL/BK/CL - 1 pcs GN/PK/IYL/WH)

code: 12 pcs unicolors **415347** (CL/BK/PK/BL/YL)

- CUSTOM FIT MOUTHPIECE
- VARIOUS COLOR OPTIONS
- HIGH COMFORT
- FITS ON ALL REGULATORS
- STRAP INCLUDED



CL BK PK GN BL YL IYL WH

### JAX-S

code: 12 pcs **415354**

- SMALL SIZE CUSTOM FIT MOUTHPIECE
- HIGH COMFORT
- FITS ON ALL REGULATORS
- WHITE COLOR
- STRAP INCLUDED



### REGULAR MOUTHPIECE KIT

code: **415335**

- THE STANDARD MARES MOUTHPIECE
- STRAP INCLUDED
- FITS ON ALL MARES REGULATORS



### SMALL MOUTHPIECE KIT

code: **415111**

- SMALL SIZE MARES MOUTHPIECE
- STRAP INCLUDED
- FITS ON ALL MARES REGULATORS



### LP HOSES

		LP HOSE WITHOUT HOSE PROTECTORS					1 <sup>ST</sup> STAGE HOSE PROTECTORS	2 <sup>ND</sup> STAGE HOSE PROTECTORS
REGULATORS	Abyss 22 Navy	46201396	1/2"	RUBBER	BLACK	80 cm	46201249	46200846
	Epic Adj 82X							46201313
	Fusion 72X							46201313
	Ultra Adj 82X	46201379	3/8"	SUPERFLEX	BLACK	75 cm		46201313
	Ultra 72X							46201313
	Dual Adj 52X							46201473
	Dual 15X							46201473
	Loop 72 X - Loop 15 X	46201665	3/8"	RUBBER	BLACK	110 cm		46201473
Rover 15X - Rover 25	46201382	3/8"	RUBBER	BLACK	80 cm	46201473		
OCTOPUS	Epic Adj						46201249	46201339
	Fusion							46201339
	Ultra Adj	46201381	3/8"	SUPERFLEX	YELLOW	100 cm		46201339
	Ultra							46201339
	Dual Adj							46201473
	Dual							46201473
	Abyss Navy	46201383	3/8"	RUBBER	YELLOW	100 cm		46200846
	Rover							46201473
Loop	46201666	3/8"	RUBBER	YELLOW	110 cm	46201473		
Air Control	46201379	3/8"	SUPERFLEX	BLACK	75 cm	46201473		

SPECIAL LENGTH							
Regulator hose	46200984	3/8"	SUPERFLEX	BLACK	210 cm		
	46200985	1/2"	SUPERFLEX	BLACK	210 cm		
	46200986	3/8"	SUPERFLEX	YELLOW	210 cm		
	46201393	3/8"	RUBBER	BLACK	210 cm		
	46201394	3/8"	RUBBER	BLACK	56 cm		

1<sup>ST</sup> STAGES



**82X PVD**

- Balanced diaphragm design
- Swivel turret
- 2 HP 7/16" UNF ports
- 5 LP 3/8" UNF ports



Epic Adj



**82X**

- Balanced diaphragm design
- Swivel turret
- 2 HP 7/16" UNF ports
- 5 LP 3/8" UNF ports



Ultra Adj



**72X**

- Balanced diaphragm design
- Vertical and Radial Lp Ports (Pat. Pending)
- 2 HP 7/16" UNF ports
- 8 LP 3/8" UNF ports



Ultra



Fusion



Loop



**52X**

- Balanced diaphragm design
- 2 HP 7/16" UNF ports
- 4 LP 3/8" UNF ports



Dual Adj



**22X CWD KIT**

- Balanced diaphragm design
- 2 HP 7/16" UNF ports
- 1 LP 1/2" UNF port (primary)
- 3 LP 3/8" UNF ports



Abyss Navy II



**15X**

- Balanced diaphragm design
- 2 HP 7/16" UNF ports
- 4 LP 3/8" UNF ports



Dual



Rover



Loop



**2S**

- Piston design
- 1 HP 7/16" UNF port
- 4 LP 3/8" UNF ports



Rover



Regulator		Epic Adj 82X	Ultra Adj 82X	Ultra 72X	Fusion 72X	Loop 72X	Abyss 22 Navy II	Dual Adj 52X	Dual 15X	Loop 15X	Rover 15X	Rover 2S
<b>Code</b>		416247	416250	416251	416252	416253	416171	416257	416258	416241	416236	416220
1st stage	Diaphragm	■	■	■	■	■	■	■	■	■	■	
	Piston											■
All metal technology		■			■		■					
Ultralight techno polymer			■	■		■		■	■	■	■	■
DFC - Dynamic flow control		■	■	■	■	■	■	■	■	■	■	■
NCC - Natural convection channel								■				
AST - Auto sealing technology		■	■	■	■	■		■				
Swivel turret		■	■									
OPD - Tilted HP ports		■	■									
Vertical LP				■	■	■						
Twin power		■	■	■	■							
VAD - Vortex assisted design (*SVAD)		■	■	■	■	■ (+)	■	■	■	■ (+)	■	■
Adjustable breathing comfort		■	■					■				
PAD - Pneumatically assisted design		■	■					■				
Mesh grid							■				■	■
Fluid dynamic deflector											■	■
Superflex hose		■	■	■	■			■	■			
PVD finishing		■										
Pearl finishing			■	■	■	■		■				
Sandblasted							■		■	■	■	■
1 <sup>st</sup> stage Weight (g)	INT	964	964	882	882	882	850	687	772	772	772	608
	DIN 300 bar	790	790	708	708	708	685	513	598	598	598	432
2 <sup>nd</sup> stage Weight (g)		329	192	190	327	199	269	185	183	199	200	200
Total Weight (g) (including hose)	INT	1429	1292	1208	1345	1256	1337	1002	1085	1146	1117	987
	DIN 300 bar	1255	1118	1034	1171	1082	1172	828	911	972	943	808



Octopus		Epic Adj	Ultra Adj	Ultra	Fusion	Loop	Abyss Navy	Dual Adj	Dual	Rover	Air Control
<b>Code</b>		416550	416553	416554	416544	416548	416546	416555	416556	416505	416893
All metal technology		■			■		■				
Ultralight techno polymer			■	■		■		■	■	■	■
Twin power		■	■	■	■						
VAD - Vortex assisted design (*SVAD)		■	■	■	■	■ (+)	■	■	■	■	■
Adjustable breathing comfort		■	■					■			
PAD - Pneumatically assisted design		■	■					■			
Mesh grid		■					■			■	■
Fluid dynamic deflector										■	■
Superflex hose		■	■	■	■			■	■		■
Total weight (g) (including hose)		483	346	344	481	374	427	359	357	375	-



# GENIUS

**NEW**

code: 414139

- NEW ZH-L16C ALGORITHM WITH GRADIENT FACTORS AND PREDICTIVE MULTIGAS
- NITROX AND TRIMIX CAPABLE, UP TO 5 GASES
- FULL COLOR HIGH-RESOLUTION DISPLAY
- FULL TILT DIGITAL COMPASS WITH BEARING MEMORY AND STOPWATCH
- HOSELESS TANK DATA INTEGRATION FOR UP TO FIVE TRANSMITTERS
- COLOR CODED TANK PRESSURE FOR AT-A-GLANCE READABILITY
- BOTTOM TIMER MODE WITH RESETTABLE AVERAGE DEPTH AND STOPWATCH
- DECOMPRESSION DIVE PLANNER WITH ADDITIONAL SURFACE INTERVAL FUNCTION
- BRILLIANT LOGBOOK WITH MULTIPLE GRAPHS
- LOGBOOK CAPACITY MORE THAN 1000 HOURS OF DIVE PROFILE AT 5-SECOND SAMPLING RATE
- SMART BATTERY MANAGEMENT SYSTEM WITH 40 HOURS DIVETIME PER FULL CHARGE
- BLUETOOTH CONNECTION FOR DIRECT CONNECTION TO SMARTPHONE
- NIGHT MODE FUNCTION
- MAP VIEWING FUNCTION DURING THE DIVE
- TISSUE SATURATION GRAPH WITH DETAILED INFORMATION
- UNDERWATER MENU ALLOWS CERTAIN SETTINGS TO BE CHANGED DURING THE DIVE
- FUTURE DECO AND RUNAWAY DECO ALARM (PROPRIETARY)



# INSTRUMENTS

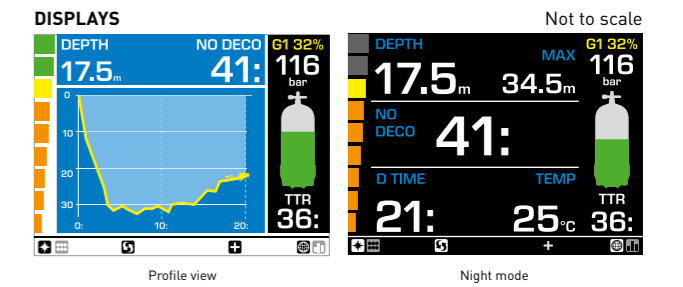

### TECHNICAL FEATURES

Battery	Type	18650 Lithium Ion polymers
	Duration	40 hours dive time/500 recharge cycles
Nitrox	EAN from 21% to 99%	
Trimix	Hypoxic, Normoxic	

### ACCESSORIES

	code	page
Led Tank Module	414319	27

### DETAILS



Led Tank Module 414319 (optional)

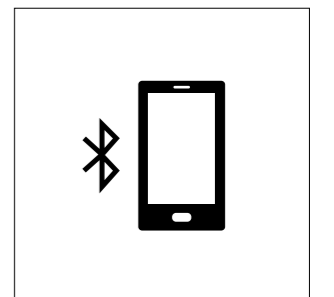

Bluetooth connection

## QUAD AIR

code: 414169

- MAGNIFICENTLY CLEAR DISPLAY WITH JUMBO SIZE INFORMATION
- HOSELESS TANK DATA INTEGRATION FOR UP TO THREE TRANSMITTERS
- THREE-ROW LAYOUT COMPRISES ALL RELEVANT DATA INCLUDING TANK PRESSURE
- TWO CUSTOMIZABLE FIELDS FOR ANCILLARY INFORMATION
- FOUR BUTTONS FOR INTUITIVE USER INTERFACE
- MIRRORED BUTTON FUNCTION DURING DIVE
- RUNAWAY DECO ALARM
- MULTIGAS CAPABLE
- DECOMPRESSION DIVE PLANNER WITH USER ADJUSTABLE SURFACE INTERVAL
- LONG BATTERY LIFE, USER REPLACEABLE



## QUAD

code: 414134

- MAGNIFICENTLY CLEAR DISPLAY WITH JUMBO SIZE INFORMATION
- TWO CUSTOMIZABLE FIELDS FOR ANCILLARY INFORMATION
- FOUR BUTTONS FOR INTUITIVE USER INTERFACE
- MIRRORED BUTTON FUNCTION DURING DIVE
- OPTION TO VIEW DIVE TIME INCLUDING SECONDS
- RUNAWAY DECO ALARM
- MULTIGAS CAPABLE
- DECOMPRESSION DIVE PLANNER WITH USER ADJUSTABLE SURFACE INTERVAL
- LONG BATTERY LIFE, USER REPLACEABLE



### COLOR VARIATIONS



BKBK BKWH BKYL BKBL

### TECHNICAL FEATURES

Battery	Type	CR2450
	Duration	150 dives
Nitrox	EAN from 21% to 99%	

### ACCESSORIES

	code	page
Led Tank Module	414319	27
Bluelink Pro	414317	30
Dive Link 2 USB	414316	30
Display Protector	415182	27

### TECHNICAL FEATURES

Battery	Type	CR2450
	Duration	200-300 dives
Nitrox	EAN from 21% to 99%	

### ACCESSORIES

	code	page
Bluelink Pro	414317	30
Dive Link 2 USB	414316	30
Display Protector	415182	27

## SMART

code: 414129

- FREEDIVING MODE (APNEA) WITH DEDICATED ALARMS
- FULL FEATURED NITROX DIVE COMPUTER WITH TWO GAS CAPABILITY
- BOTTOM TIMER MODE WITH RESETTABLE AVERAGE DEPTH AND STOPWATCH
- LOGBOOK CAPACITY IN EXCESS OF 40 HOURS OF DIVE PROFILE AT 5-SECOND SAMPLING RATE (SCUBA) AND MEMORY FUNCTION FOR FREEDIVING
- DECOMPRESSION DIVE PLANNER WITH ADDITIONAL SURFACE INTERVAL FUNCTION
- UPGRADEABLE FIRMWARE
- COMPLETE WATCH FUNCTIONS: STOPWATCH, WAKE-UP ALARM, SECOND TIME ZONE, DATE
- USER-REPLACEABLE BATTERY



### COLOR VARIATIONS



BKBK BKGR BKRD BKWH WHLM WHLL

### TECHNICAL FEATURES

Battery	Type	CR2430
	Duration	200-300 dives over a three year time span
Nitrox	EAN from 21% to 99%	

### ACCESSORIES

	code	page
Bluelink Pro	414317	30
Dive Link 2 USB	414316	30
Display Protector	415173	27
Strap Extension	44201190	27

## SMART AIR

code: 414138

- HOSELESS TANK DATA INTEGRATION FOR UP TO THREE TRANSMITTERS
- GRAPHIC AND NUMERIC DISPLAY OF TANK PRESSURE
- THREE-ROW LAYOUT COMPRISES ALL RELEVANT DATA INCLUDING TANK PRESSURE
- MULTIGAS CAPABLE
- OPTION TO VIEW DIVE TIME INCLUDING SECONDS
- TWO CUSTOMIZABLE FIELDS FOR ANCILLARY INFORMATION
- LOGBOOK CAPACITY OF 95 HOURS OF DIVE PROFILE
- DECOMPRESSION DIVE PLANNER WITH ADDITIONAL SURFACE INTERVAL FUNCTION
- COMPLETE WATCH FUNCTIONS
- FREEDIVING MODE (APNEA) WITH DEDICATED ALARMS
- BOTTOM TIMER MODE WITH RESETTABLE AVERAGE DEPTH AND STOPWATCH
- USER-REPLACEABLE BATTERY



### TECHNICAL FEATURES

Battery	Type	CR2450
	Duration	200 hours dive time
Nitrox	EAN from 21% to 99%	

### ACCESSORIES

	code	page
Led Tank Module	414319	27
Bluelink Pro	414317	30
Dive Link 2 USB	414316	30
Display Protector	415173	27
Strap Extension	44201190	27

## MATRIX

code: 414170

- COMPLETE WATCH FUNCTIONS: WAKE-UP ALARM, SECOND TIME ZONE, DATE AND CHOICE OF ANALOG OR DIGITAL TIME DISPLAY
- FULL DOT MATRIX DISPLAY
- FULL TILT DIGITAL COMPASS WITH BEARING MEMORY AND STOPWATCH
- ABILITY TO VIEW DIVE PROFILE DURING THE DIVE
- BOTTOM TIMER MODE WITH RESETTABLE AVERAGE DEPTH AND STOPWATCH
- LOGBOOK WITH DIVE GRAPH INCLUDING DEPTH PROFILE
- LOGBOOK CAPACITY 35 HOURS OF DIVE PROFILE AT 5-SECOND SAMPLING RATE
- ICE (IN CASE OF EMERGENCY) FUNCTION
- INCLUDES INTERFACE AND SOFTWARE FOR DOWNLOADING TO PC OR MAC
- RECHARGEABLE BATTERY
- UPGRADEABLE FIRMWARE



### COLOR VARIATIONS



BK BK WH WH

### TECHNICAL FEATURES

Battery	Type	Custom Lithium Ion polymer
	Duration	15 hours diving / 4 week standby / 500 recharging cycles
Nitrox		EAN from 21% to 99%

### ACCESSORIES

	code	page
Metal Strap	414811	27
Display Protector	415173	27
Strap Extension	44200966	27

## PUCK PRO +

NEW

code: 414135

- SLIM DESIGN FOR A PERFECT FIT
- INTUITIVE USER INTERFACE WITH ONE-BUTTON SIMPLICITY
- LOGBOOK CAPACITY 35 HOURS OF DIVE PROFILE AT 5-SECOND SAMPLING RATE
- UPGRADEABLE FIRMWARE
- BOTTOM TIMER MODE WITH RESETTABLE AVERAGE DEPTH AND STOPWATCH
- USER-REPLACEABLE BATTERY



### COLOR VARIATIONS



BK BK BK WH YL BK BL BK GR BK WH BK

### TECHNICAL FEATURES

Battery	Type	CR2450
	Duration	200-300 dives
Nitrox		EAN from 21% to 99%

### ACCESSORIES

	code	page
Bluelink Pro	414317	30
Dive Link 2 USB	414316	30

## LED TANK MODULE

code: 414319

- TRANSMITS TANK INFORMATION
- COLOR LED FOR QUICK TANK CHECK ON THE SURFACE
- COLOR LED ALERTS BUDDY OF LOW AIR SITUATION DURING DIVE
- PERMANENT PAIRING
- EN250:2014 CERTIFIED TO 300BAR
- BATTERY TYPE: CR123A, USER REPLACEABLE



## MATRIX STRAP EXTENSION

code: 44200966

- FOR USE WITH THICK WET OR DRY SUITS
- FOR MATRIX ONLY



## MATRIX METAL STRAP

code: 414811

- STYLISH BLACK/SILVER STAINLESS STEEL STRAP EXTENSION
- FOR USE WITH WETSUITS
- LOCK SYSTEM
- FOR MATRIX ONLY



## QUAD DISPLAY PROTECTOR

code: 415182

- EASY TO INSTALL
- PREVENTS FROM SCRATCHES
- SOFT AND DURABLE
- ULTRA CLEAR



## MATRIX / SMART DISPLAY PROTECTOR

code: 415173

- PERFECT FIT AND EASY TO INSTALL
- PREVENTS FROM SCRATCHES, DIRT AND SAND
- SOFT AND DURABLE
- ULTRA CLEAR
- A PACK CONTAINS 2 PIECES
- ALSO FITS THE SMART



## SMART STRAP EXTENSION

code: 44201190

- FOR USE WITH THICK WET OR DRY SUITS
- FOR SMART ONLY



**PUCK AIR**

code: 414161

code: 414162 - 414163 Southern Hemisphere

- COMPACT YET FULL FEATURED AIR INTEGRATED DIVE COMPUTER
- GAS TIME CALCULATION
- SEGMENT DISPLAY WITH DOT MATRIX INSERT
- INTUITIVE USER INTERFACE WITH ONE-BUTTON SIMPLICITY
- AVAILABLE WITH ANALOG COMPASS
- LOGBOOK CAPACITY 35 HOURS OF DIVE PROFILE AT 20-SECOND SAMPLING RATE
- USER-REPLACEABLE BATTERY
- MULTIPLE LANYARD ATTACHMENT POINTS

PUCK AIR  
STANDARD VERSIONPUCK AIR  
WITH COMPASS**TECHNICAL FEATURES**

Battery	Type	CR2450
	Duration	200-300 dives
Nitrox		EAN from 21% to 50%

**ACCESSORIES**

	code	page
Drak USB Interface	414308	30

**MISSION 1C WRIST COMPASS**

code: 414404

- OIL BATH
- SIDE VIEW WINDOW
- WRIST MOUNT CONSOLE

**PUCK CONSOLES**

code: 414420 Mission Puck 2

code: 414421 Mission Puck 3

- COMPACT CONSOLE WITH FULL FEATURED COMPUTER AND ANALOG PRESSURE GAUGE
- AVAILABLE WITH ANALOG COMPASS
- INTUITIVE USER INTERFACE WITH ONE-BUTTON SIMPLICITY
- LOGBOOK CAPACITY 35 HOURS OF DIVE PROFILE AT 5-SECOND SAMPLING RATE
- USER-REPLACEABLE BATTERY
- MULTIPLE LANYARD ATTACHMENT POINTS



MISSION PUCK 2

MISSION PUCK 3

**TECHNICAL FEATURES**

Battery	Type	CR2450
	Duration	200-300 dives
Nitrox		EAN from 21% to 50%

**ACCESSORIES**

	code	page
Drak USB Interface	414308	30

**HANDY COMPASS**

code: 414504 - 414506 Southern hemisphere

- OIL BATH
- SIDE VIEW WINDOW
- SPECIAL HOUSING FOR CLIPPING TO BCD

**MISSION 1**

code: 414417

- BRASS CASE
- TECHNOPOLYMER WINDOW
- PHOSPHORESCENT DIAL FACE
- PROTECTIVE RUBBER CONSOLE
- MULTIPLE ATTACHMENT POINTS

**MISSION 2**

code: 414418

- PRESSURE GAUGE:
- BRASS CASE
- TECHNOPOLYMER WINDOW
- PHOSPHORESCENT DIAL FACE

DEPTH GAUGE:

- OIL BATH
- PHOSPHORESCENT DIAL FACE
- MAX DEPTH INDICATOR
- LINEAR SCALE

CONSOLE:

- PROTECTIVE RUBBER COVER WITH MULTIPLE ATTACHMENT POINTS

**MISSION 2C**

code: 414423

- PRESSURE GAUGE:
- BRASS CASE
- TECHNOPOLYMER WINDOW
- PHOSPHORESCENT DIAL FACE

COMPASS:

- OIL BATH
- SIDE VIEW WINDOW

CONSOLE:

- PROTECTIVE RUBBER COVER WITH MULTIPLE ATTACHMENT POINTS

**MISSION 3**

code: 414419

- PRESSURE GAUGE:
- BRASS CASE
- TECHNOPOLYMER WINDOW
- PHOSPHORESCENT DIAL FACE

DEPTH GAUGE:

- OIL BATH
- PHOSPHORESCENT DIAL FACE
- MAX DEPTH INDICATOR
- LINEAR SCALE

COMPASS:

- OIL BATH
- SIDE VIEW WINDOW

CONSOLE:

- PROTECTIVE RUBBER COVER WITH MULTIPLE ATTACHMENT POINTS

**MISSION DIGITAL CHRONO**

code: 414814

- DIGITAL CHRONOGRAPH WITH BACK LIGHT
- WATER RESISTANT 20atm/293psi OR 200m/660ft
- HIGH-QUALITY SWISS QUARTZ MOVEMENT
- DAILY ALARM AND HOURLY TIME SIGNAL
- COUNTDOWN TIMER
- DIGITAL TIMEZONE AND DATE
- SECOND DIGITAL TIMEZONE
- FLUORESCENT DIGITS
- STAINLESS STEEL

**MISSION PRO**

code: 414813

- WATER RESISTANT 20atm/293psi OR 200m/660ft
- HIGH-QUALITY SWISS QUARTZ MOVEMENT
- FLUORESCENT DIGITS
- SILICONE STRAP
- STAINLESS STEEL CASE





### BLUELINK PRO

code: 414317

- TO DOWNLOAD THE LOGBOOK OF A DIVE COMPUTER USING THE BLUETOOTH LOW ENERGY TECHNOLOGY (QUAD, QUAD AIR, PUCK PRO +, SMART, SMART AIR)
- REQUIRES THE DIVESSI APP (ANDROID, IOS)



### DIVE LINK 2 USB

code: 414316

- FOR DOWNLOADING THE DIVE COMPUTER MEMORY TO PC OR MAC (QUAD, QUAD AIR, PUCK PRO +, SMART, SMART AIR)
- REQUIRED SOFTWARE: DIVE ORGANIZER (PC) OR DIVERS DIARY (MAC)



### DRAK USB

code: 414308

- FOR DOWNLOADING THE DIVE COMPUTER MEMORY TO PC OR MAC (ALL PUCK CONSOLES)
- REQUIRED SOFTWARE: DIVE ORGANIZER (PC) OR DIVERS DIARY (MAC)



### DIVE ORGANIZER

- FULL-FEATURED LOGBOOK MANAGEMENT SOFTWARE
- ALLOWS UPGRADING OF FIRMWARE ON COMPATIBLE DIVE COMPUTERS
- ALLOWS UPLOADING OF MAPS AND IMAGES TO ICON HD
- FEATURES TISSUE SATURATION GRAPH WITH DETAILED EVOLUTION DURING THE DIVE
- FOR PC ONLY



### DIVERS DIARY

- FULL-FEATURED LOGBOOK MANAGEMENT SOFTWARE
- ALLOWS UPGRADING OF FIRMWARE ON COMPATIBLE DIVE COMPUTERS
- FEATURES TISSUE SATURATION GRAPH WITH DETAILED EVOLUTION DURING THE DIVE
- FOR MAC ONLY

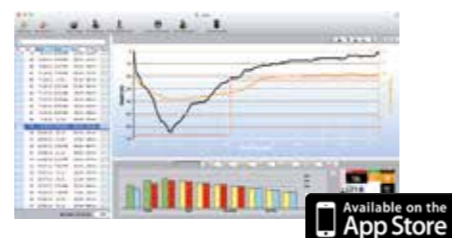

Computer	Genius	Quad Air	Quad	Smart	Smart Air	Matrix	Puck Pro +	Puck Air	Puck Air with compass	Mission Puck 2	Mission Puck 3
Code	414139	414169	414134	414129	414138	414170	414135	414161	414162 NO 414163 SO	414420	414421
Colors	BK BK	BK BK	BK BK, BK WH, BK YL, BK BL	BK BK, BK GR, BK RD, BK WH, WH LM, WH LL	BK BK	BK BK, WH WH	BK BK, BK WH, YL BK, BL BK, GR BK, WH BK	-	-	-	-
ZH-L16C GF	■										
RGBM		■	■	■	■	■	■	■	■	■	■
Trimix	■										
LCD color display	■										
Full dot matrix						■					
Segment display		■	■	■	■		■	■	■	■	■
Air integrated	■	■			■			■	■		
Graphic and numeric tank pressure	■				■						
Gas switching	■	■	■	■	■	■	■				
Software upgradeability	■	■	■	■	■	■	■				
USB charger	■					■					
One button control							■	■	■	■	■
Mineral glass	■	■	■	■	■	■	■				
Max displayed depth	150 m (492 ft)	150 m (492 ft)	150 m (492 ft)	150 m (492 ft)	150 m (492 ft)	150 m (492 ft)	150 m (492 ft)	150 m (492 ft)	150 m (492 ft)	150 m (492 ft)	150 m (492 ft)
Rechargeable batteries	■					■					
Dive hours per charge	40 hr					15 hr					
User replaceable batteries		■	■	■	■		■	■	■	■	■
Residual nitrogen reset	■	■	■	■	■	■	■	■	■	■	■
Option to exclude audible alarms	■	■	■	■	■	■	■	■	■	■	■
Ascent rate indicator	■	■	■	■	■	■	■	■	■	■	■
Memory capacity	1000 hr	> 100 hr	38 hr	> 40 hr	95 hr	35 hr	36 hr	36 hr	36 hr	36 hr	36 hr
Profile sampling rates	5 s	5 s	5 s	5 s	5 s	5 s	5 s	20 s	20 s	5 s	5 s
Dual time				■	■	■					
Stopwatch	■	■ **	■ **	■	■	■ *					
Daily alarm	■			■	■	■					

\* Dive mode  
\*\* Bottom timer mode

**MAGELLAN****NEW**

code: 417226

- THE TRUE TRAVEL BCD: EXTREMELY LIGHTWEIGHT
- INTEGRATED QUICK RELEASE WEIGHT SYSTEM
- OPTIONAL TRIM WEIGHT (TO BE PLACED ON THE TANK BAND)
- FOLDABLE WITH NO RIGID BACKPACK
- STRAP LOOP BACKPACK FEATURE FOR EASY ADJUSTMENT
- 1 ROLL-UP POCKET
- CONCAVE ERGONOMIC SHOULDERS (PATENT PENDING): INCREASED COMFORT IN CHEST/SHOULDER AREA
- TROUBLE FREE FOR FEMALE DIVERS

**TECHNICAL FEATURES**

Sizes	XXS/XS	S/M	L/XL
Weight	2,3 kg / 5.0 lb	2,3 kg / 5.0 lb	2,4 kg / 5.3 lb
Buoyancy	180 N (18,3 kg / 38 lb)	180 N (18,3 kg / 38 lb)	180 N (18,3 kg / 38 lb)

**ACCESSORIES**

	code	page
Trim Weight	417964	39

**DETAILS**

Quick release buckle system



Optional Trim Weights



Ergonomic concave shoulders



Roll up pocket

**BCD'S**

## DRAGON SLS / KAILA SLS

code Dragon SLS: **417223**code Kaila SLS: **417363**

- SUPERBLY COMFORTABLE AND STABLE YET TOUGH AND DURABLE
- AIRCELL SLIDES ON SHOULDERS FOR INCREASED COMFORT WHEN INFLATED
- POSITION OF THE CORRUGATED HOSE RETAINING EPAULETTE CAN BE ADJUSTED
- HIGH LIFT AIRCELL WITH "DRAGON" WINGLETS
- SMART TRIM WEIGHT POSITIONING
- SLS WEIGHT SYSTEM
- SWIVEL BUCKLES: 50mm ON THE DRAGON, 40mm ON THE KAILA
- HIGH CAPACITY CARGO POCKETS WITH STRETCH PANELS
- ADJUSTABLE CUMMERBUND
- MONOPLATE BACKPACK FITS SINGLE OR DOUBLE TANKS
- VISUAL CONFIRMATION OF PROPER WEIGHT POUCH INSERTION
- PERSONALIZABLE LABEL ON WEIGHT POCKETS



### TECHNICAL FEATURES

Sizes	XS	S	M	L	XL
<b>Weight</b>	4,2 kg / 9.2 lb	4,2 kg / 9.2 lb	4,4 kg / 9.7 lb	4,5 kg / 9.9 lb	4,75 kg / 10.5 lb
<b>Buoyancy</b>	130 N (13,8 kg / 30 lb)	150 N (16 kg / 35 lb)	180 N (18,3 kg / 38 lb)	200 N (21 kg / 46 lb)	230 N (23,9 kg / 53 lb)

She Dives Sizes	XXS	XS	S	M	L
<b>Weight</b>	4,1 kg / 9 lb	4,2 kg / 9.2 lb	4,2 kg / 9.2 lb	4,4 kg / 9.7 lb	4,5 kg / 9.9 lb
<b>Buoyancy</b>	110 N (10,8 kg / 24 lb)	130 N (13,8 kg / 30 lb)	150 N (16 kg / 35 lb)	180 N (18,3 kg / 38 lb)	200 N (21 kg / 46 lb)

### ACCESSORIES

	code	page
<b>BCD attachment Kit</b>	415178	40
<b>Tank strap set for doubles</b>	415090	39

### DETAILS



"Dragon" aircell



High capacity cargo pockets with stretch panels



Adjustable epaulette



50mm swivel buckles

## PURE SLS

code: **417361**

- COMFORTABLE AND STABLE BACK BUOYANCY BC WITH 18kg LIFT (40 lbs)
- STREAMLINED
- SWIVEL SHOULDER BUCKLES
- SMART TRIM WEIGHT POSITIONING
- SLS WEIGHT SYSTEM
- ROLL-DOWN CARGO POCKET
- WAIST STRAP ALLOWS MAXIMUM ADJUSTABILITY
- CUSTOMIZABLE AND TRAVEL FRIENDLY
- MONOPLATE BACKPACK FITS SINGLE OR DOUBLE TANKS
- VISUAL CONFIRMATION OF PROPER WEIGHT POUCH INSERTION
- PERSONALIZABLE LABEL ON WEIGHT POCKETS



### TECHNICAL FEATURES

Sizes	XS	S	M	L	XL
<b>Weight</b>	3,6 kg / 7.9 lb	3,7 kg / 8.1 lb	3,7 kg / 8.1 lb	3,8 kg / 8.3 lb	3,8 kg / 8.3 lb
<b>Buoyancy</b>	170 N (18,1 kg / 40 lb)	170 N (18,1 kg / 40 lb)	170 N (18,1 kg / 40 lb)	170 N (18,1 kg / 40 lb)	170 N (18,1 kg / 40 lb)

### ACCESSORIES

	code	page
<b>BCD attachment kit</b>	415178	40
<b>Tank strap set for doubles</b>	415090	39
<b>Crotch Strap</b>	415744	39
<b>Optional Cargo Pocket</b>	417961	39

## BOLT SLS

code: **417362**

- SUPERBLY COMFORTABLE AND STABLE BACK BUOYANCY BC WITH 21kg LIFT (46 lbs)
- STREAMLINED
- SWIVEL SHOULDER BUCKLES
- SMART TRIM WEIGHT POSITIONING
- SLS WEIGHT SYSTEM
- ROLL-DOWN CARGO POCKET
- ADJUSTABLE CUMMERBUND
- TRAVEL FRIENDLY
- MONOPLATE BACKPACK FITS SINGLE OR DOUBLE TANKS
- VISUAL CONFIRMATION OF PROPER WEIGHT POUCH INSERTION
- PERSONALIZABLE LABEL ON WEIGHT POCKETS



### TECHNICAL FEATURES

Sizes	XS	S	M	L	XL
<b>Weight</b>	3,6 kg / 7.9 lb	3,7 kg / 8.1 lb	3,7 kg / 8.1 lb	3,9 kg / 8.6 lb	3,9 kg / 8.6 lb
<b>Buoyancy</b>	200 N (21 kg / 46 lb)	200 N (21 kg / 46 lb)	200 N (21 kg / 46 lb)	200 N (21 kg / 46 lb)	200 N (21 kg / 46 lb)

### ACCESSORIES

	code	page
<b>BCD attachment Kit</b>	415178	40
<b>Tank strap set for doubles</b>	415090	39

**QUANTUM SLS**

code: 417357

- MONOPLATE BACKPACK FITS SINGLE TANK OR DOUBLES
- SWIVEL BUCKLES AND D-RING ATTACHMENT ON SIDE LOBE
- SLS WEIGHT SYSTEM
- VISUAL CONFIRMATION OF PROPER WEIGHT POUCH INSERTION
- PERSONALIZATION LABEL ON WEIGHT POUCHES
- STRETCH CARGO POCKETS
- OPENINGS ON SIDE LOBES FOR HOSE STORAGE
- TRIM WEIGHT POCKETS
- OPTIONAL BC ATTACHMENT KIT
- OPTIONAL TANK STRAP SET FOR DOUBLES UP TO 2 X 12l / 2 X 80cuft

**TECHNICAL FEATURES**

Sizes	XS	S	M	L	XL
<b>Weight</b>	4,2 kg / 9.2 lb	4,2 kg / 9.2 lb	4,4 kg / 9.7 lb	4,5 kg / 9.9 lb	4,6 kg / 10.1 lb
<b>Buoyancy</b>	120 N (12,2 kg / 27 lb)	130 N (13,8 kg / 30 lb)	150 N (16 kg / 35 lb)	180 N (18,3 kg / 38 lb)	200 N (21 kg / 46 lb)

**ACCESSORIES**

	code	page
<b>BCD Attachment Kit</b>	415178	40
<b>Tank strap set for doubles</b>	415090	39

**HYBRID AT**

code: 417334

- FOLDABLE BACKPACK
- AIRTRIM FOR FAST AND INTUITIVE BUOYANCY CONTROL
- MRS PLUS MODULAR INTEGRATED WEIGHT SYSTEM

**TECHNICAL FEATURES**

Sizes	XS/S	M/L	XL
<b>Weight</b>	3,9 kg / 8.6 lb	4 kg / 8.8 lb	4,2 kg / 9.2 lb
<b>Buoyancy</b>	145 N (14,8 kg / 32,6 lb)	200 N (21 kg / 46 lb)	235 N (24 kg / 52.9 lb)

**ACCESSORIES**

	code	page
<b>BCD attachment Kit</b>	415178	40

**PRESTIGE SLS**

code: 417224 BL

code: 417225 WH

- EXCELLENT LIFT CAPACITY
- LIGHT, STRONG AND DURABLE DENIER 420
- IMPROVED FIT: SWIVELING BUCKLES, SHOULDERS, LOW-CUT AIRCELL
- SLS INTEGRATED WEIGHT SYSTEM
- 3-DIMENSIONAL ZIPPERED SELF-DRAINING POCKETS
- 2 REAR TRIM WEIGHT POCKETS
- REDUCED WEIGHT: TRAVEL FRIENDLY

**TECHNICAL FEATURES**

Sizes BL	XS	S	M	L	XL
<b>Weight</b>	3,4 kg / 7.5 lb	3,5 kg / 7.7 lb	3,85 kg / 8.5 lb	3,9 kg / 8.6 lb	4 kg / 8.8 lb
<b>Buoyancy</b>	120 N (12,2 kg / 27 lb)	130 N (13,8 kg / 30 lb)	150 N (16 kg / 35 lb)	180 N (18,3 kg / 38 lb)	200 N (21 kg / 46 lb)

Sizes WH	XXS	XS	S	M	L
<b>Weight</b>	3,3 kg / 7.3 lb	3,4 kg / 7.5 lb	3,5 kg / 7.7 lb	3,85 kg / 8.5 lb	3,9 kg / 8.6 lb
<b>Buoyancy</b>	100 N (10,8 kg / 24 lb)	120 N (12,2 kg / 27 lb)	130 N (13,8 kg / 30 lb)	150 N (16 kg / 35 lb)	180 N (18,3 kg / 38 lb)

**ACCESSORIES**

	code	page
<b>BCD attachment Kit</b>	415178	40
<b>Tank strap set for doubles</b>	415090	39

**PRIME**

code: 417364

- IDEAL FOR THOSE WHO WANT TO GET STARTED WITH THEIR DIVING ADVENTURE
- STANDARD BCD
- EXCELLENT BUOYANCY AND FIT
- LIGHT, STRONG AND DURABLE DENIER 420
- STOWAGE FOR OCTOPUS AND PRESSURE GAUGE
- MONOPLATE BACKPACK
- 2 LARGE CARGO POCKETS
- UPGRADEABLE INTEGRATED WEIGHT SYSTEM

**TECHNICAL FEATURES**

Sizes	XS	S	M	L	XL
<b>Weight</b>	2,5 kg / 5.5 lb	2,6 kg / 5.7 lb	2,8 kg / 6.2 lb	2,8 kg / 6.2 lb	2,9 kg / 6.4 lb
<b>Buoyancy</b>	140 N (14,2 kg / 31.3 lb)	150 N (16 kg / 35 lb)	160 N (16,3 kg / 35.9 lb)	200 N (21 kg / 46 lb)	235 N (24 kg / 52.9 lb)

**ACCESSORIES**

	code	page
<b>Tank strap set for doubles</b>	415090	39
<b>Standard Weight System - Small</b>	417963	39
<b>Standard Weight System - Large</b>	417962	39

# SCUBA RANGER

**NEW**

code: 417227

- KID/JUNIOR BCD WITH A DEDICATED BACKPACK
- 2 COMFORTABLE VELCRO POCKETS
- SPECIALLY DESIGNED OCTOPUS AND PRESSURE GAUGE POCKETS
- OPTIONAL TRIM WEIGHTS TO BE PLACED ON TANK STRAP
- TANK BAND: DEDICATED ADAPTABLE SHORTER TANK BAND TO FIT SMALLER TANKS
- 1 SIZE FITS ALL, FROM 8 - 12 YEARS, THANKS TO A DEDICATED ADJUSTMENT SYSTEM



## TECHNICAL FEATURES

Sizes	3XS (one size)
Weight	1,8kg / 3.9 lb
Buoyancy	80 N (8,3 kg / 18 lb)

## ACCESSORIES

	code	page
Trim Weight	417964	39

## DETAILS



Optional Trim Weights



Octopus and gauge pockets

## SLS SLIDE&LOCK SYSTEM

code: 417959 - SMALL: 4kg / 9lbs (PAIR)\*

code: 417960 - LARGE: 6kg / 13lbs (PAIR)\*

- STURDY ZIPPERED POCKET
- EASY TO SLIDE INTO POCKET
- VISUAL AID TO SEE IF SYSTEM IS PROPERLY ENGAGED
- SAFEST SYSTEM AVAILABLE
- EASY TO USE WITH THICK GLOVES



## MRS PLUS

code: 417955 - SMALL: 4kg / 9lbs (PAIR)

code: 417954 - LARGE: 6kg / 13lbs (PAIR)

- ZIPPERED POCKET
- INTERNAL VELCRO FOR MULTIPLE SECTIONS



## TRIM WEIGHT

**NEW**

code: 417964 - (PAIR)

- EASY TO INSTALL ON TANK BAND
- DOUBLE LOOP TO FIT PERFECTLY ON THE BAND
- PERFECT BUOYANCY
- LESS WEIGHT ON THE BELT
- WEIGHT CAPACITY: 2kg EACH



## STANDARD WEIGHT SYSTEM

**NEW**

code: 417963 - SMALL: 4kg / 9lbs (PAIR)

code: 417962 - LARGE: 6kg / 13lbs (PAIR)

- ADD-ON TO UPGRADE BCD WITH STANDARD BUCKLE WEIGHT SYSTEM
- ZIPPERED POCKET
- EASY USE WITH THICK GLOVES



## KIT MRS PLUS

code: 417958 (PAIR)

- OPTIONAL FOR UPGRADING BCDS WITH MRS PLUS
- EASY TO INSTALL
- ZIPPERED POCKET
- INTERNAL VELCRO FOR MULTIPLE SECTIONS
- LARGE WEIGHT CAPACITY: 6kg / 13lbs



## CARGO POCKET

code: 417961

- HIGH VOLUME POCKET
- REPLACES SLS SYSTEM
- FOR PURE SLS ONLY



## TANK STRAP SET FOR DOUBLES

code: 415090

- ALLOWS TWIN TANKS UP TO 2 X 12L / 2 X 80cuft ON SELECTED BCDS



## CROTCH STRAP

code: 415744

- CAN BE USED WITH BACKMOUNTED BCDS
- ULTIMATE STABILITY



\* Pat pending

### LANYARD STAINLESS SPIRAL WITH RING

code: 415732

- STAINLESS STEEL SPIRAL CABLE
- PROVIDES EXTENSION MORE THAN 50 cm/20 in
- QUICK RELEASE BUCKLE
- TO AVOID LOOSE ACCESSORIES



### LANYARD SPIRAL WITH RING

code: 415717

- SPIRAL CABLE PROVIDES MORE THAN 50 cm/20 in EXTENSION
- STAINLESS STEEL RING
- QUICK RELEASE BUCKLE



### LANYARD OPEN LOOP

code: 415722

- MULTI FUNCTIONAL LANYARD WITH OPEN LOOP
- THE LOOP ALLOWS WIDE ATTACHMENT FUNCTIONALITY
- MALE/FEMALE QUICK RELEASE BUCKLE



### LANYARD MALE/FEMALE

code: 415716

- MULTI FUNCTIONAL
- PLUG IN AND USE WITH MOST STANDARD BUCKLE SYSTEMS
- FAST LEASH OPENING FOR SIMPLE ATTACHMENT



### STANDARD RETRACTOR

code: 415715

- STAINLESS STEEL CABLE
- HEAVY DUTY HOOKS ON BOTH SIDES
- MORE THAN 60 cm/23,5 in WHEN EXTENDED



### CONSOLE HOLDER WITH VELCRO

code: 415718

- STRONG VELCRO TO HOLD AND RELEASE WHEN NEEDED
- QUICK RELEASE SYSTEM USED FOR CONSOLE AND OCTOPUS
- QUICK ADJUSTING ROPE LEASH FOR FLEXIBLE FASTENING



### HOSE RETAINER

code: 415157

- HEAVY DUTY HOOKS
- SWIVEL SOLUTION
- TWO POSITIONS TO HANG HOSES



### BCD ATTACHMENT KIT

code: 415178\*

- IDEAL SOLUTION FOR YOUR EXTENSION POLE
- EASY TO INSTALL
- FITS ONTO MARES BCD'S



\* Pat pending



BCD	Magellan	Dragon SLS	Kaila SLS	Pure SLS	Bolt SLS	Quantum SLS	Hybrid AT	Prestige SLS	Prime	Scuba Ranger	
Code	417226	417223	417363	417361	417362	417357	417334	417224 BL	417225 WH	417364	417227
Sizes	XXS/XS - S/M - L/XL	XS - S - M - L - XL	XXS - XS - S - M - L	XS - S - M - L - XL	XS - S - M - L - XL	XS - S - M - L - XL	XS/S - M/L - XL	XS - S - M - L - XL	XXS - XS - S - M - L	XS - S - M - L - XL	3XS
Fusion bladder		■	■				■				
Classic bladder						■		■		■	■
Backmounted	■			■	■						
Ergo inflator	■	■	■	■	■	■		■		■	■
Airtrim							■				
Monoplate backpack		■	■	■	■	■		■		■	■
Foldable backpack	■						■				
Suspension system							■				
Material	Cordura®420	Cordura®420	Cordura®420	Cordura®420	Cordura®420	Cordura®420	Cordura®420	Cordura®420	Cordura®420	Cordura®420	Cordura®420
D-rings	Stainless steel		5	5	7	6	6		2		
	Aluminium	4						6			
	Heavy-duty Technopolymer	1					3		4	5	2
Weight (size L)	kg	2,4	4,5	4,4	3,8	3,9	4,5	4	3,9	2,8	1,8*
	lb	5,3	9,9	9,7	8,3	8,6	9,9	8,8	8,6	6,2	3,9
Buoyancy	3XS										80 N (8,3 kg / 18 lb)
	XXS	180 N (18,3 kg / 38 lb)		110 N (10,8 kg / 24 lb)					100 N (10,8 kg / 24 lb)		
	XS	130 N (13,8 kg / 30 lb)	130 N (13,8 kg / 30 lb)	130 N (13,8 kg / 30 lb)	170 N (18,1 kg / 40 lb)	200 N (21 kg / 46 lb)	120 N (12,2 kg / 27 lb)	145 N (14,8 kg / 32,6 lb)	120 N (12,2 kg / 27 lb)	120 N (12,2 kg / 27 lb)	140 N (14,2 kg / 31,3 lb)
	S	180 N (18,3 kg / 38 lb)	150 N (16 kg / 35 lb)	150 N (16 kg / 35 lb)	170 N (18,1 kg / 40 lb)	200 N (21 kg / 46 lb)	130 N (13,8 kg / 30 lb)	145 N (14,8 kg / 32,6 lb)	130 N (13,8 kg / 30 lb)	130 N (13,8 kg / 30 lb)	150 N (16 kg / 35 lb)
	M	180 N (18,3 kg / 38 lb)	180 N (18,3 kg / 38 lb)	180 N (18,3 kg / 38 lb)	170 N (18,1 kg / 40 lb)	200 N (21 kg / 46 lb)	150 N (16 kg / 35 lb)	200 N (21 kg / 46 lb)	150 N (16 kg / 35 lb)	150 N (16 kg / 35 lb)	160 N (16,3 kg / 35,9 lb)
	L	180 N (18,3 kg / 38 lb)	200 N (21 kg / 46 lb)	200 N (21 kg / 46 lb)	170 N (18,1 kg / 40 lb)	200 N (21 kg / 46 lb)	180 N (18,3 kg / 38 lb)	200 N (21 kg / 46 lb)	180 N (18,3 kg / 38 lb)	180 N (18,3 kg / 38 lb)	200 N (21 kg / 46 lb)
XL	180 N (18,3 kg / 38 lb)	230 N (23,9 kg / 53 lb)		170 N (18,1 kg / 40 lb)	200 N (21 kg / 46 lb)	200 N (21 kg / 46 lb)	235 N (24 kg / 52,9 lb)	200 N (21 kg / 46 lb)		235 N (24 kg / 52,9 lb)	
SLS	417959 (small - max 4 kg)		XS - S	XXS - XS - S	XS - S - M - L - XL	XS - S - M	XS - S		XS - S	XXS - XS - S	
	417960 (large - max 6 kg)		M - L - XL	M - L		L - XL	M - L - XL		M - L - XL	M - L	
MRS Plus	417955 (small - max 4 kg)						XS/S				
	417954 (large - max 6 kg)						M/L - XL				
Standard Buckle	417963 (small - max 4 kg)	XXS/XS - S/M								Optional	
	417962 (large - max 6 kg)	L/XL									

\* 3XS



# SUITS

## SEAL SKIN

code: 412369 Man

code: 412370 She Dives

- THE REVOLUTION IN COLD WATER SUITS
- INCREASED THERMAL COMFORT WITH S-SEAL TECHNOLOGY
- GLIDESKIN WRISTS AND ANKLES
- ZIPPERS ON ANKLES
- COMFORTABLE NECK CLOSURE
- SUPRATLEX KNEEPAD
- EASY DONNING AND DOFFING THANKS TO ULTRASTRETCH NEOPRENE
- INSTRUMENT GRIP AREA ON BOTH WRISTS
- INTEGRATED BUCKLE ON THE LEG FOR HOOD ATTACHMENT OR ATTACHMENT OF THE DEDICATED SMART POCKET (SOLD SEPARATELY)



### TECHNICAL FEATURES

Thickness	6 mm							
Fabric type	Ultrastretch Neoprene							
Man Sizes		2	3	4	5	6	7	8
She Dives Sizes	1	2	3	4	5	6		

### DETAILS



Smart Pocket Retainer



Silver Back Zip

## FLEXA THERM

code: 412069 Man

code: 412070 She Dives

- MAXIMUM THERMAL COMFORT, PERFECT FIT
- HORIZONTAL SOFT AND FLEXIBLE WATERPROOF MASTER SEAL ZIP ON BACK
- HANDY POCKETS WITH ZIP AND D-RING
- HOOD WITH FAST AIR RELEASE AND EAR EQUALIZATION SYSTEM



### TECHNICAL FEATURES

Thickness	6.5 mm							
Fabric type	Ultrastretch Neoprene							
Man Sizes	2	3	4	5	6	7	8	
She Dives Sizes	1	2	3	4	5			

## FLEXA Z-THERM

NEW

code: 412367 Man

code: 412368 She Dives

- THE ULTIMATE EXPRESSION OF SEMIDRY SUITS: DONNING/DOFFING, INCLUDING CLOSING OF ZIPPER, CAN BE DONE AUTONOMOUSLY
- DIAGONAL G-LOCK FRONT ZIP WITH INSIDE FLAPS TO INCREASE THERMAL COMFORT AND SKIN PROTECTION IN THE ZIP AREA
- 100% ULTRASTRETCH WITH STRATEGICALLY PLACED PANELS AND SPECIAL CUT
- TRILASTIC CONCEPT FOR A BETTER FIT IN THE MOST CRITICAL AREAS (WAIST + NECK/BACK + ARMPIT)
- INNOVATIVE TELESCOPIC SYSTEM: GREAT SIZE CUSTOMIZATION THROUGH CROTCH ADJUSTMENT
- INCREASED THERMAL COMFORT IN THE MOST CRITICAL AREAS AND INCREASED WAIST AND LUMBAR COMFORT
- COMPACT, STRETCHY POCKET INTEGRATED IN THE SUIT ON THE RIGHT THIGH
- GASKETS ON WRISTS AND ANKLES DELIVER A BETTER SEAL WHICH REDUCES WATER ENTRY



### TECHNICAL FEATURES

Thickness	7 mm							
Fabric type	Ultrastretch Neoprene							
Man Sizes	2	3	4	5	6	7	8	
She Dives Sizes	1	2	3	4	5	6		



Telescopic system



Diagonal zipper



# FLEXA



**8-6-5 mm**  
code: **412337 Man**  
code: **412339 She Dives**

**5-4-3 mm**  
code: **412338 Man**  
code: **412340 She Dives**

**3-2-2 mm**  
code: **412348 Man**  
code: **412349 She Dives**

- THE ULTIMATE EXPRESSION OF TRILASTIC MATERIAL DESIGN
- VARIED THICKNESSES STRATEGICALLY PLACED IN DIFFERENT AREAS OF THE BODY
- NEW SOFT ERGONOMIC CUSTOM CLOSURE
- BACK AND SHOULDERS COMFORT SYSTEM: AN ADDITIONAL LAYER OF NEOPRENE STITCHED IN THE BACK FOR ADDED COMFORT AND PROTECTION
- FRONT ZIP WITH SMOOTH NEOPRENE FLAP FOR GREATER COMFORT AND ISOLATION
- INTEGRATED BUCKLE ON THE LEG FOR HOOD ATTACHMENT OR ATTACHMENT OF THE DEDICATED FLEXA SMART POCKET (SOLD SEPARATELY)
- INSTRUMENT GRIPS ON BOTH WRISTS



Shoulder color changes with suit thickness

**TECHNICAL FEATURES**

<b>Thickness</b>	8-6-5 / 5-4-3 / 3-2-2 mm							
<b>Fabric type</b>	Ultrastretch Neoprene							
<b>Man Sizes</b>		2	3	4	5	6	7	8
<b>She Dives Sizes</b>	1	2	3	4	5	6		

# PIONEER

**7 mm**  
code: **412346 Man**  
code: **412347 She Dives**

**5 mm**  
code: **412344 Man**  
code: **412345 She Dives**

- NON-RUBBER CUSTOM CLOSURE
- ZIPPERS ON THE ANKLES (ONLY ON THE 7 mm VERSION) MAKE DONNING AND DOFFING EFFORTLESS
- THE HOOD VENTING SYSTEM ASSISTS THE RELEASE OF AIR, OPTIMIZING EQUALIZATION AND COMFORT
- NEW NECK CLOSURE WITH ANTI-ABRASION VELCRO PREVENTS WETSUIT DAMAGE
- INSTRUMENT GRIPS ON BOTH WRISTS
- HOOD KEEPER D-RING ON THE RIGHT LEG
- KNEEPAD IN ANTI-ABRASIVE MATERIAL



**TECHNICAL FEATURES**

<b>Thickness</b>	7 mm / 5 mm							
<b>Fabric type</b>	Neoprene & Ultrastretch Neoprene							
<b>Man Sizes</b>		2	3	4	5	6	7	8
<b>She Dives Sizes</b>	1	2	3	4	5	6		

# DUAL

code: **412375 Man**  
code: **412376 She Dives**

- TRADITIONAL COMBINATION OF A LONG JOHN AND A JACKET
- THICKEST NEOPRENE AREA CONCENTRATED ON CHEST AND BACK AREAS WHERE THERMAL PROTECTION IS MOST NEEDED
- GLIDESKIN WRIST AND ANKLE SEALS
- LEAVES ARMS AND LEGS WITH A FEELING OF FREEDOM AND MOBILITY
- STRATEGICALLY PLACED ELASTIC INSERTS
- INSTRUMENT GRIP AREA ON BOTH WRISTS
- KNEEPAD IN ANTI-ABRASIVE MATERIAL



**TECHNICAL FEATURES**

<b>Thickness</b>	5 mm							
<b>Fabric type</b>	Neoprene							
<b>Man Sizes</b>		2	3	4	5	6	7	8
<b>She Dives Sizes</b>	1	2	3	4	5	6		

## REEF

code: 412382 Man  
code: 412383 She Dives

- NEW MODERN DESIGN WITH SHOULDER GRIP AREA
- COOL, STRETCHY AND IDEAL FOR TEMPERATE WATER
- ERGONOMIC, COMFORTABLE VELCRO CLOSURE AND BACK ZIP PULLER
- WRIST, ANKLE AND NECK SEALS ENRICHED WITH AQUASTOP FINISH

## CORAL

code: 412386 Man  
code: 412387 She Dives

- COMFORTABLE SECOND SKIN FOR TROPICAL DIVES
- EASY DONNING AND DOFFING
- CAN ALSO BE WORN AS AN UNDERSUIT
- ELASTIC BANDS ON WRISTS AND ANKLES FOR BETTER FIT ALONE OR UNDER A SUIT
- METALITE FABRIC INSIDE WITH HEAT RETAINING EFFECT



### TECHNICAL FEATURES

Thickness	3 mm							
Fabric type	Neoprene							
Man Sizes	2	3	4	5	6	7	8	
She Dives Sizes	1	2	3	4	5	6		

### TECHNICAL FEATURES

Thickness	0.5 mm							
Fabric type	Neoprene							
Man Sizes	2	3	4	5	6	7	8	
She Dives Sizes	1	2	3	4	5	6		

## FLEXA CORE

code: 412342 Man  
code: 412343 She Dives

- ULTRA-ELASTIC SHORTY WITH ATTACHED HOOD FOR GREATER THERMAL COMFORT
- COMPLETES THE FAMILY OF FLEXA SUITS, BUT CAN ALSO BE USED WITH ANY MARES SUIT
- CAN BE USED AS A STAND-ALONE PRODUCT
- INTEGRATED BUCKLE ON THE LEG FOR HOOD ATTACHMENT OR ATTACHMENT OF A CUSTOMIZED POCKET (SOLD SEPARATELY)



### TECHNICAL FEATURES

Thickness	4 mm							
Fabric type	Ultrastretch Neoprene							
Man Sizes	2	3	4	5	6	7	8	
She Dives Sizes	1	2	3	4	5	6		

## 2nd SKIN SHORTY

code: 412371 Man  
code: 412372 She Dives

- MADE WITH METALITE (HEAT REFLECTING AND HEAT RETAINING PROPERTIES)
- BEST WORN UNDERNEATH THE STEAMER
- EXTREMITIES IN GLIDE SKIN ON THE LEGS, TOGETHER WITH THE ERGONOMIC NECK CLOSURE AND THE 0,5 mm HOOD, CREATE AN EXTREMELY WATER-RESISTANT SHORTY
- CAN ALSO BE USED AS A SNORKELING SUIT



### TECHNICAL FEATURES

Thickness	1.5 mm							
Fabric type	Ultrastretch Neoprene / Metalite inside							
Man Sizes	2	3	4	5	6	7	8	
She Dives Sizes	1	2	3	4	5	6		

## REEF SHORTY

code: 412384 Man  
code: 412385 She Dives

- COOL, STYLISH, LIGHTWEIGHT AND EXCELLENT FOR WARM WATER DIVES AND LONG SNORKELING SESSIONS
- HIGH LEVEL OF FINISH ON ALL DETAILS INCLUDING NECK CUSTOM CLOSURE AND BACK ZIP PULLER
- ERGONOMIC COMFORTABLE VELCRO CLOSURE AND BACK ZIP PULLER
- AQUASTOP FINISH ON ARMS AND THIGHS



## FLEXA VEST

code: 412537 Man  
code: 412538 She Dives

- INCREASES HEAT RETENTION IN COLD WATER DIVING
- IDEAL FOR WEARING UNDER FLEXA SUITS
- LOW COMPRESSION NEOPRENE ON THE TOP OF THE HEAD



### TECHNICAL FEATURES

Thickness	3 mm						
Fabric type	Ultrastretch Neoprene						
Man Sizes	2	3	4	5	6	7	8
She Dives Sizes	1	2	3	4	5	6	

## GOLD SKIN

code: 412411 Man  
code: 412412 She Dives

- NEOPRENE WITH OUTER COVERING AND OPEN-CELL INTERIOR WITH GOLD SKIN COATING



### TECHNICAL FEATURES

Thickness	2 mm						
Fabric type	Neoprene with open cell interior gold skin coating						
Man Sizes	2	3	4	5	6	7	8
She Dives Sizes	1	2	3	4	5	6	

### TECHNICAL FEATURES

Thickness	2.5 mm						
Fabric type	Neoprene						
Man Sizes	2	3	4	5	6	7	8
She Dives Sizes	1	2	3	4	5	6	

## SCUBA RANGER

code: 412373 Jacket  
code: 412374 Long John

- DEDICATED KID'S TWIN SUIT: LONG-SLEEVED, HOODED JACKET AND LONG JOHN (SOLD SEPARATELY)
- JACKET AND LONG JOHN CAN BE WORN TOGETHER OR SEPARATELY ACCORDING TO WATER TEMPERATURE
- DEDICATED DESIGN AND COLOR FOR KIDS: SHOULDERS AND ZIPPERS IN LIME
- VARIED THICKNESSES STRATEGICALLY PLACED IN DIFFERENT AREAS OF THE BODY FOR COMFORT AND FREEDOM OF MOVEMENT
- EASY DONNING AND DOFFING



### TECHNICAL FEATURES

Thickness	5 mm			
Fabric type	Neoprene			
Sizes Junior	-3	-2	-1	0

## THERMO GUARD SHORTY

code: 412536

- ALWAYS HANDY
- EXTREMELY VERSATILE PRODUCT THAT CAN BE USE AS A FIRST LAYER OR AS A STANDALONE IN WARM WATERS
- METALITE FABRIC INSIDE
- THE PERFECT CHOICE FOR SWIMMING POOLS OR SNORKELING
- JUNIOR SIZES WITH DEDICATED GRAPHICS AVAILABLE

## THERMO GUARD

### LONG SLEEVE

code: 412550 Man

code: 412554 She Dives

### SHORT SLEEVE

code: 412549 Man

code: 412553 She Dives

### SHORTS

code: 412534 Man

code: 412535 She Dives

- BODY CORE COMFORT FOR ALL WATER SPORTS
- EASY TO WEAR AND SMOOTH ON YOUR SKIN
- METALITE COATING HELPS RETAIN HEAT FOR SUPERIOR WARMTH
- FLAT STITCHING FOR COMFORTABLE CONTACT WITH YOUR BODY



UPF 50+

### TECHNICAL FEATURES

Thickness	1.5 mm									
Fabric type	Neoprene / Metalite inside									
Man Sizes (BL)				2	3	4	5	6	7	8
She Dives Sizes (AQ)			1	2	3	4	5	6		
Sizes Junior (YL)	-3	-2	-1	0						

UPF 50+

### TECHNICAL FEATURES

Thickness	0.5 mm							
Fabric type	Neoprene / Metalite inside							
Man Sizes		XS	S	M	L	XL	2XL	3XL
She Dives Sizes	XXS	XS	S	M	L	XL	2XL	

## ULTRA SKIN

NEW

### MAN

code: 412394 - Steamer

code: 412389 - Long Sleeve

code: 412393 - Short Sleeve

code: 412391 - Sleeveless with hood

code: 412392 - Sleeveless without hood

code: 412398 - Shorts

### SHE DIVES

code: 412420 - Steamer

code: 412397 - Long Sleeve

code: 412419 - Short Sleeve

code: 412399 - Sleeveless with hood

code: 412418 - Sleeveless without hood

code: 412390 - Shorts

- INNOVATIVE UNDERSUIT WITH THERMAL COMFORT PROPERTIES
- ULTRASKIN TECHNOLOGY COMBINES 3 DIFFERENT LAYERS: FLEECE INSIDE FOR THE BEST COMFORT, A WINDPROOF AND BREATHABLE MEMBRANE AND A STRETCHY LAYER OUTSIDE FOR THE PERFECT FIT AND FREEDOM OF MOVEMENT
- SUITABLE AS A WETSUIT UNDERSUIT, A DRY SUIT AND FOR WATERSPORTS
- A FULL RANGE OF STYLES TO MEET EVERYONE'S NEEDS, IN MALE AND FEMALE VERSIONS



UPF 50+

### TECHNICAL FEATURES

Thickness	-						
Fabric type	Outer: Lycra - Mid: PU Membrane - Inner: Fleece						
Man Sizes		S	M	L	XL	2XL	3XL
She Dives Sizes	XS	S	M	L	XL	2XL	

## RASH GUARD UPF BLOCK 80+

code: 412413 Man BL

code: 412414 She Dives LIL

code: 412415 Junior YL

- LONG-SLEEVED RASH GUARD UPF BLOCK 80+ AVAILABLE IN A MAN'S, WOMAN'S AND JUNIOR VERSION WITH DEDICATED CUT
- FOR ALL KINDS OF WATERSPORTS
- COOL, LIGHTWEIGHT MATERIAL
- FAST DRYING
- FLAT SEAM CONSTRUCTION FOR COMFORT



**UPF 30+**

### TECHNICAL FEATURES

Thickness	-							
Fabric type	Nylon / Spandex							
Man Sizes		XS	S	M	L	XL	2XL	3XL
She Dives Sizes	XXS	XS	S	M	L	XL	2XL	
Sizes Junior			S	M	L	XL		

## RASH GUARD

### LONG SLEEVE

code: 412551 Man

code: 412555 She Dives

### SHORT SLEEVE

code: 412552 Man

code: 412556 She Dives

### SHORTS

code: 412547 Man

code: 412548 She Dives

- FOR ALL KINDS OF WATER SPORTS
- COOL, LIGHTWEIGHT MATERIAL
- FAST DRYING
- FLAT SEAM CONSTRUCTION FOR COMFORT



**UPF 50+**

### TECHNICAL FEATURES

Thickness	-							
Fabric type	Polyester / Spandex							
Man Sizes		XS	S	M	L	XL	2XL	3XL
She Dives Sizes	XXS	XS	S	M	L	XL	2XL	

## RASH GUARD LOOSE FIT

### LONG SLEEVE

code: 412539 LM Man / 412539 BL Man

code: 412541 LIL She Dives / 412541 AQ She Dives

### SHORT SLEEVE

code: 412540 LM Man / 412540 BL Man

code: 412542 LIL She Dives / 412542 AQ She Dives

- BE COOL AND PROTECTED
- LOOSE FIT STYLE
- NEW VIBRANT COLORS
- FAST DRYING
- IDEAL AS AN UNDERGARMENT OR BY ITSELF
- FLAT SEAM CONSTRUCTION FOR COMFORT



**UPF 30+**

### TECHNICAL FEATURES

Thickness	-							
Fabric type	Nylon / Spandex							
Man Sizes		XS	S	M	L	XL	2XL	3XL
She Dives Sizes	XXS	XS	S	M	L	XL	2XL	

## TRILASTIC STEAMER

code: 412545 Man

code: 412546 She Dives

- SNORKELING WITHOUT WORRIES
- PROTECTS ALMOST YOUR ENTIRE BODY SURFACE FROM SOLAR RAYS OR OCCASIONAL SEA ENCOUNTERS
- CAN BE USED AS THE PERFECT LAYER UNDER A RENTAL SUIT
- STIRRUPS EQUIPPED FOR SECURE PLACEMENT



**UPF 50+**

### TECHNICAL FEATURES

Thickness	-							
Fabric type	Polyester / Spandex							
Man Sizes		XS	S	M	L	XL	2XL	3XL
She Dives Sizes	XXS	XS	S	M	L	XL	2XL	

## PHOTOSUIT

code: 412525

- IDEAL FOR PHOTOGRAPHERS
- TO BE WORN OVER A WETSUIT
- 4 COLORS AVAILABLE



**UPF 50+**

### TECHNICAL FEATURES

Thickness	-			
Fabric type	Polyester / Spandex			
Sizes Unisex	2	3	4	

\*Ages indicated in the table are purely for reference

## RASH GUARD KID

### BOY

code: **412543 Long Sleeve**

code: **412559 Short Sleeve**

### GIRL

code : **412544 Long Sleeve**

code: **412560 Short Sleeve**

- FOR ALL KINDS OF WATER SPORTS
- COOL, LIGHTWEIGHT MATERIAL
- FAST DRYING
- FLAT SEAM CONSTRUCTION FOR COMFORT
- DEDICATED KID CUT

## RASH GUARD JUNIOR

### BOY

code: **412500 Long Sleeve**

code: **412506 Short Sleeve**

### GIRL

code: **412501 Long Sleeve**

code: **412507 Short Sleeve**

- FOR ALL KINDS OF WATER SPORTS
- COOL, LIGHTWEIGHT MATERIAL
- FAST DRYING
- FLAT SEAM CONSTRUCTION FOR COMFORT
- DEDICATED JUNIOR CUT



**UPF 50+**

### TECHNICAL FEATURES

Thickness	-				
Fabric type	Polyester / Spandex				
Sizes	XS	S	M	L	XL
Ages*	2/3	3/4	4/5	5/6	6/7

**UPF 50+**

### TECHNICAL FEATURES

Thickness	-				
Fabric type	Polyester / Spandex				
Sizes	XS	S	M	L	XL
Ages*	8/9	9/10	10/11	11/12	12/13

## NEOPRENE GLUE

code: **415108**

- IDEAL FOR URGENT AND QUICK WETSUIT REPAIRS
- MADE IN COMPLIANCE WITH LATEST REGULATIONS
- 20ml



## TIZIP LUBRICANT STICK

code: **415728**

- FOR SEMI-DRY TIZIP
- TO PREVENT DRYING
- TO INCREASE DURABILITY



## MINERAL TALCUM

code: **415748 Desk Exhibitor (6pcs)**

- HIGH QUALITY TALCUM TO PROTECT LATEX AND RUBBER PARTS
- IDEAL FOR MAINTENANCE AND THE CARE OF DRYSUITS AND WETSUITS
- MAKES DONNING SUITS EASIER
- PREVENTS IRRITATION
- 125 gr



## SMART POCKET

code: **412341**

- CAN BE INSTALLED ON ALL NEW MARES SUITS FEATURING THE INTEGRATED SMART POCKET SYSTEM VIA AN EASY AND INTUITIVE CLIP SYSTEM
- INTEGRATED GRAPHIC PERFECTLY MATCHES ALL MARES SUITS
- GRIP PROTECTION SYSTEM TO AVOID LOOSENING WHEN DIVING OR DAMAGE TO THE SUIT



## FLEXA HOOD

**NEW**

code: **412823**

- A VENTING SYSTEM HELPS RELEASE AIR, OPTIMIZING EQUALIZATION AND COMFORT
- HOOD ATTACHMENT SYSTEM



### TECHNICAL FEATURES

Thickness	6-4-3 mm				
Size	XS	S	M	L	XL

## CLASSIC SOCK

**NEW**

code: **412635**



### TECHNICAL FEATURES

Thickness	3 mm					
Size	XXS	XS	S	M	L	XL

**FLEXA DS**

**NEW**

code: 412638



**TECHNICAL FEATURES**

Thickness	6.5 mm						
Size	5	6	7	8	9	10	11

**FLEXA DS**

**NEW**

code: 412637



**TECHNICAL FEATURES**

Thickness	5 mm								
Size	5	6	7	8	9	10	11	12	13

**SEAL SKIN**

**NEW**

code: 412640



**TECHNICAL FEATURES**

Thickness	5 mm							
Size	5	6	7	8	9	10	11	12

**CLASSIC NG**

**NEW**

code: 412634



**TECHNICAL FEATURES**

Thickness	5 mm										
Size	3	4	5	6	7	8	9	10	11	12	13

**EQUATOR**

**NEW**

code: 412636



**TECHNICAL FEATURES**

Thickness	2 mm										
Size	3	4	5	6	7	8	9	10	11	12	13

**PURE**

**NEW**

code: 412639



**TECHNICAL FEATURES**

Thickness	2 mm										
Size	3	4	5	6	7	8	9	10	11	12	13

**FLEXA FIT**

**NEW**

code: 412725



**TECHNICAL FEATURES**

Thickness	6.5 mm					
Size	XXS	XS	S	M	L	XL

**FLEXA FIT**

**NEW**

code: 412724



**TECHNICAL FEATURES**

Thickness	5 mm					
Size	XXS	XS	S	M	L	XL

**SEAL SKIN**

**NEW**

code: 412727



**TECHNICAL FEATURES**

Thickness	5-4-3 mm					
Size	XXS	XS	S	M	L	XL

**FLEXA CLASSIC**

**NEW**

code: 412723



**TECHNICAL FEATURES**

Thickness	3 mm					
Size	XXS	XS	S	M	L	XL

**FLEXA TOUCH**

**NEW**

code: 412726



**TECHNICAL FEATURES**

Thickness	2 mm		
Size	XS/S	M/L	XL/XXL

**AMARA**

**NEW**

code: 412722



**TECHNICAL FEATURES**

Thickness	2 mm					
Size	XXS	XS	S	M	L	XL

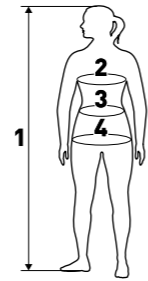
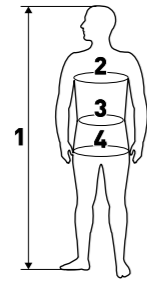

WETSUIT ≥ 5mm

IT	2	3	4	5	6	7	8
EU	S	M	L	XL	XXL	3XL	4XL
USA	S	M	L	XL	XXL	XXXL	
1	175 / 5'9"	178 / 5'10"	181 / 5'11"	184 / 6'	187 / 6'2"	190 / 6'3"	193 / 6'4"
2	93 / 37"	97,5 / 38"	101,5 / 40"	105,5 / 42"	110 / 43"	114 / 45"	118 / 46"
3	73 / 29"	77,5 / 31"	81,5 / 32"	86 / 34"	90 / 35"	94 / 37"	98 / 39"
4	91 / 36"	95,5 / 38"	99,5 / 39"	104 / 41"	108 / 43"	112 / 44"	116 / 46"

IT	1	2	3	4	5	6	7
EU	XS	S	M	L	XL	XXL	3XL
USA	4	6	8	10	12	14	16
1	164 / 5'5"	167 / 5'6"	170 / 5'7"	173 / 5'8"	176 / 5'9"	179 / 5'10"	182 / 6'
2	77,5 / 31"	81,5 / 32"	85,5 / 34"	89,5 / 35"	93,5 / 37"	97,5 / 38"	101,5 / 40"
3	67 / 26"	71 / 28"	75 / 30"	79 / 31"	83 / 33"	87 / 34"	91 / 36"
4	84 / 33"	88 / 35"	92 / 36"	96 / 38"	100 / 39"	104 / 41"	108 / 43"

WETSUIT ≤ 3mm

IT	2	3	4	5	6	7	8
EU	S	M	L	XL	XXL	3XL	4XL
USA	S	M	L	XL	XXL	XXXL	
1	176 / 5'9"	179 / 5'10"	182 / 6'	185 / 6'1"	188 / 6'2"	191 / 6'3"	194 / 6'4"
2	92 / 36"	96,5 / 38"	100,5 / 40"	105 / 41"	109 / 43"	113,5 / 45"	117,5 / 46"
3	71,5 / 28"	75,5 / 30"	80 / 32"	84 / 33"	88,5 / 35"	92,5 / 36"	97 / 38"
4	91 / 36"	95 / 37"	99,5 / 39"	103,5 / 41"	108 / 43"	112 / 44"	116 / 46"

IT	1	2	3	4	5	6	7
EU	XS	S	M	L	XL	XXL	3XL
USA	4	6	8	10	12	14	16
1	163,5 / 5'4"	166,5 / 5'6"	169,5 / 5'7"	172,5 / 5'8"	175,5 / 5'9"	178,5 / 5'10"	181,5 / 5'11"
2	75 / 30"	79 / 31"	83 / 33"	87 / 34"	91 / 36"	95 / 37"	99 / 39"
3	66 / 26"	70 / 28"	74 / 29"	78 / 31"	82 / 32"	86 / 34"	90 / 35"
4	82,5 / 32"	86,5 / 34"	90,5 / 36"	94,5 / 37"	98,5 / 39"	102,5 / 40"	106,5 / 42"

SCUBA RANGER

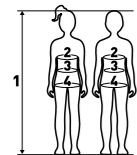

	-3	-2	-1	0
1	119 / 47"	129 / 50"	140 / 55"	150 / 59"
2	59 / 23"	64 / 25"	70 / 27"	75 / 30"
3	55 / 21"	59 / 23"	63 / 24"	67 / 26"
4	65 / 26"	73 / 29"	77 / 30"	85 / 33"

THERMO GUARD SHORTY UNISEX

IT	EU	CHEST	WAIST	HIPS	TOLERANCE
-3	8 A	56 / 22"	52 / 20"	66 / 26"	± 2 / ± 0.8"
-2	10 A	61 / 24"	56 / 22"	75 / 30"	± 2 / ± 0.8"
-1	12 A	67 / 26"	60 / 24"	79 / 31"	± 2 / ± 0.8"
0	14 A	73 / 29"	65 / 26"	87 / 34"	± 2 / ± 0.8"
1	XS	86 / 34"	65 / 26"	85 / 33"	± 2 / ± 0.8"
2	S	90 / 35"	70 / 28"	89 / 35"	± 2 / ± 0.8"
3	M	94 / 37"	74 / 29"	94 / 37"	± 2 / ± 0.8"
4	L	99 / 39"	78 / 31"	98 / 39"	± 2 / ± 0.8"
5	XL	103 / 41"	82 / 32"	102 / 40"	± 2 / ± 0.8"
6	XXL	107 / 42"	86 / 34"	106 / 42"	± 2 / ± 0.8"
7	3XL	111 / 44"	91 / 36"	111 / 44"	± 2 / ± 0.8"

NEOPRENE BOOTS

	EUROPE	USA	JAPAN
4XS	34/35	3	-
3XS	35/36	4	-
2XS	36/37	5	23 cm
XS	38	6	24 cm
S	39/40	7	25 cm
M	40/41	8	26 cm
L	41/42	9	27 cm
XL	43	10	28 cm
2XL	44/45	11	29 cm
3XL	45/46	12	-
4XL	47	13	-



Suit	Seal Skin		Flexa Therm		Flexa Z-Therm		Flexa					
	Man	She Dives	Man	She Dives	Man	She Dives	Man	She Dives	Man	She Dives	Man	She Dives
Model												
Code	412369	412370	412069	412070	412367	412368	412337	412339	412338	412340	412348	412349
Thickness	6		6.5		7		8 - 6 - 5		5 - 4 - 3		3 - 2 - 2	
Sizes	2-3-4-5-6 -7-8		1-2-3-4-5-6		2-3-4-5-6 -7-8		1-2-3-4-5		2-3-4-5-6 -7-8		1-2-3-4-5-6 -7-8	
For cold water	■		■		■		■		■		■	
For temperate water									■			
For warm water											■	
Back protection system							■		■		■	
Instruments grip	■				■		■		■		■	
Masterseal zip			■									
G-lock zipper:					■							
S-lock zipper	■											
Zippers on ankles	■		■									
Double cone	■		■									
Thermo plush							■		■		■	
Hood included	■		■		■							
Hood keeper	■		■		■		■		■		■	
Smart pocket	■						■		■		■	
Integrated pocket					■							
Gasket sealings			■									



Suit	Pioneer		Dual		Reef		Coral		Scuba Ranger			
	Man	She Dives	Man	She Dives	Man	She Dives	Man	She Dives	Jacket	LongJohn		
Model												
Code	412346	412347	412344	412345	412375	412376	412382	412383	412386	412387	412373	412374
Thickness	7		5		5		3		0.5		5	
Sizes	2-3-4-5-6 -7-8		1-2-3-4-5-6		2-3-4-5-6 -7-8		1-2-3-4-5-6 -7-8		2-3-4-5-6 -7-8		1-2-3-4-5-6 -7-8	
For cold water	■										■	
For temperate water			■		■						■	
For warm water							■		■		■	
Instruments grip	■		■		■							
Zippers on ankles	■										■	
Double cone	■											
Hood included	■		■									
Hood keeper	■		■									





# FINS\*

\* Please note that some items are only available while stocks last

## AVANTI PURE

code: 410027

NEW



- A 2-MATERIAL, OPEN HEEL FIN
- CAN BE USED BAREFOOT OR WITH MARES PURE BOOTIES
- SOFT AND COMFORTABLE FOOT POCKET
- ERGONOMIC HEEL PAD (PATENT PENDING) MINIMIZES PRESSURE ON THE ACHILLES' HEEL
- SPECIAL BUNGEE STRAP FOR MAXIMUM COMFORT DURING USE, WHEN DONNING AND DOFFING
- BUNGEE GUIDES SO THE STRAP IS ALWAYS PLACED IN THE RIGHT POSITION

### COLOR VARIATIONS

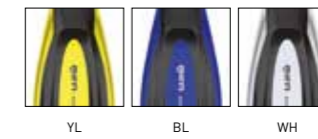

### TECHNICAL FEATURES

Sizes	SM	ML	LXL
Fit	35/38	39/43	44/47
Blade*	30 cm / 11.8 in	32 cm / 12.6 in	34 cm / 13.4 in

### DETAILS



Soft, comfortable footpocket



Bungee guides to avoid footpocket pivoting



Ergonomic heel pad



Interchangeable bungee strap

# AVANTI HC PRO

NEW

code: 410347

- SOFT ERGONOMIC FOOT POCKET WITH LATERAL INSERTS
- HYPERCHANNEL-INDUCED THRUST EFFECT WITH AN INCREASED PERFORMANCE/EFFORT RATIO
- RIDGES ON THE BACK OF THE BLADE: REINFORCE THE BLADE WHILE OPTIMIZING PIVOTING GEOMETRY
- OVERMOLDING ON THE BACK RIB FURTHER OPTIMIZES THRUST AND PERFORMANCE

### COLOR VARIATIONS



### TECHNICAL FEATURES

Sizes	36/37	38/39	40/41	42/43	44/45	46/47
Blade*	32,5 cm 12.8 in	34,5 cm 13.5 in	36 cm 14.2 in	38 cm 15 in	40 cm 15.7 in	42 cm 16.5 in

### DETAILS



Footpocket with lateral inserts

Ridges on the back



2 wider channels for increased thrust

Hyperchannel

# AVANTI HC

NEW

code: 410346

- SOFT ERGONOMIC FOOT POCKET WITH LATERAL INSERTS
- HYPERCHANNEL-INDUCED THRUST EFFECT WITH AN INCREASED PERFORMANCE/EFFORT RATIO
- RIDGES ON THE BACK OF THE BLADE: REINFORCE THE BLADE WHILE OPTIMIZING PIVOTING GEOMETRY

### COLOR VARIATIONS

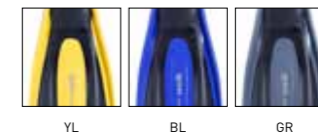

### TECHNICAL FEATURES

Sizes	36/37	38/39	40/41	42/43	44/45	46/47
Blade*	32,5 cm 12.8 in	34,5 cm 13.5 in	36 cm 14.2 in	38 cm 15 in	40 cm 15.7 in	42 cm 16,5 in

### DETAILS



Footpocket with lateral inserts

Overmolded ridges on the back



2 wider channels for increased thrust

Hyperchannel

## EXCITE / EXCITE PRO

code: 410025 EXCITE

code: 410026 EXCITE PRO

- INNOVATIVE MATERIALS FOR A MORE HARMONIOUS THRUST
- ENHANCED CHANNEL THRUST
- EXCITE: OPTIMIZED FOR LOW FATIGUE
- EXCITE PRO: OPTIMIZED FOR MAXIMUM THRUST
- COLOR COORDINATED BUNGEE STRAP



### COLOR VARIATIONS EXCITE



YL BL

### COLOR VARIATIONS EXCITE PRO



GR

### TECHNICAL FEATURES

Sizes	XS	S	R	XL
Fit	34/37	37/41	41/44	44/48
Blade*	36 cm / 14.1 in	39 cm / 15.3 in	40 cm / 15.7 in	40 cm / 15.7 in

\* From end of footpocket to end of blade

## X-STREAM

NEW

code: 410019

- BUNGEE STRAP
- RIDDLED FOOT POCKET AVOIDS "PARACHUTE EFFECT"
- NEXT GENERATION OPB
- TRI-MATERIAL BLADE CONSTRUCTION REDUCES TURBULENCE
- CHANNEL THRUST TECHNOLOGY



### COLOR VARIATIONS



YL BL RD TBK WH JPK\*\*

### TECHNICAL FEATURES

Sizes	XS	S	R	XL
Fit	34/37	37/41	41/44	44/48
Blade*	34,5 cm / 13.6 in	36 cm / 14.2 in	37 cm / 14.6 in	38 cm / 15 in

\* From end of footpocket to end of blade  
\*\* ABS Buckle

## AVANTI EXCEL

code: 410316

- ANATOMICAL FOOT POCKET
- WHALE TAIL DESIGN FOR POWERFUL FOOT-BLADE POWER TRANSMISSION
- TRI-MATERIAL BLADE WITH CHANNEL THRUST TECHNOLOGY



### COLOR VARIATIONS



YL BL SI

### TECHNICAL FEATURES

Sizes	34/35	36/37	38/39	40/41	42/43	44/45	46/47
Blade*	29,5 cm / 11.6 in	30 cm / 11.8 in	31 cm / 12.2 in	32 cm / 12.6 in	33 cm / 13 in	34 cm / 13.4 in	35,5 cm / 14 in

## VOLO POWER

code: 410008

- ABS PLUS BUCKLES
- OPB SYSTEM FOR GREAT KICKING EFFICIENCY
- CHANNEL THRUST TECHNOLOGY



## VOLO RACE

code: 410313

- ANATOMICAL FOOT POCKET
- OPB SYSTEM FOR EASY KICKING EFFICIENCY
- CHANNEL THRUST TECHNOLOGY



### COLOR VARIATIONS



YL BL SI

### TECHNICAL FEATURES

Sizes	S	R	XL
Fit	37/41	41/44	44/48
Blade*	36 cm / 14.2 in	37 cm / 14.6 in	37 cm / 14.6 in

### COLOR VARIATIONS



YL BL BGR

### TECHNICAL FEATURES

Sizes	36/37	38/39	40/41	42/43	44/45	46/47
Blade*	33,5 cm 13.2 in	33,5 cm 13.2 in	36,5 cm 14.5 in	37 cm 14.6 in	39,5 cm 15.6 in	39,5 cm 15.6 in

\* From end of footpocket to end of blade

## AVANTI QUATTRO +

code: 410003

- BUNGEE STRAP
- HI-FLEX MATERIAL OPTIMIZES BLADE'S EFFICIENCY
- 4 CHANNELS FOR GREATER THRUSTING POWER
- STABILIZING TRIM TABS



## AVANTI QUATTRO POWER

code: 410301

- ANATOMICAL FOOT POCKET
- RUBBERIZED SIDE RIBS
- 4 CHANNELS FOR GREATER THRUSTING POWER
- LONG BLADE, IDEAL FOR BOTH SCUBA AND APNEA



### COLOR VARIATIONS



YL BL BK WH LM FL

### TECHNICAL FEATURES

Sizes	S	R	XL
Fit	37/41	41/44	44/48
Blade*	37 cm / 14.6 in	38 cm / 15 in	39 cm / 15.3 in

\* From end of footpocket to end of blade

### COLOR VARIATIONS



BK

### TECHNICAL FEATURES

Sizes	40/41	42/43	44/45	46/47
Blade*	44 cm 17.3 in	45,5 cm 17.9 in	45,5 cm 17.9 in	45,5 cm 17.9 in

## AVANTI SUPERCHANNEL OH

code: 410012

- BUNGEE STRAP
- ANATOMICAL OPEN HEEL FOOT POCKET
- 3 CHANNEL DESIGN FOR ADDED PROPULSION
- RUGGED AND DURABLE CONSTRUCTION



## AVANTI SUPERCHANNEL FF

code: 410317

- ORTHOPEDIC FOOT POCKET
- TECRALENE BLADE FOR SUPERIOR PERFORMANCE AND DURABILITY
- 3 CHANNEL DESIGN FOR ADDED PROPULSION



### COLOR VARIATIONS



YL BL BK

### TECHNICAL FEATURES

Sizes	S	R	XL
Fit	37/41	41/44	44/48
Blade*	35 cm / 13.8 in	37 cm / 14.6 in	37 cm / 14.6 in

### COLOR VARIATIONS



YL BL RD WH

### TECHNICAL FEATURES

Sizes	36/37	38/39	40/41	42/43	44/45	46/47
Blade*	32 cm / 12.6 in	33 cm / 13 in	34 cm / 13.4 in	35,5 cm / 14 in	36,5 cm / 14.5 in	37 cm / 14.6 in

\* From end of footpocket to end of blade

## AVANTI TRE

code: 410302

- ORTHOPEDIC FOOT POCKET
- 3 CHANNELS FOR MAXIMUM THRUST
- MID-SIZE BLADE WITH DURABLE CONSTRUCTION
- STABILIZING TRIM TABS



### COLOR VARIATIONS



YL BL BK

### TECHNICAL FEATURES

Sizes	36/37	38/39	40/41	42/43	44/45	46/47
Blade*	31 cm / 12.2 in	33 cm / 13 in	34 cm / 13.4 in	36 cm / 14.2 in	36,5 cm / 14.5 in	37,5 cm / 14.8 in

\* From end of footpocket to end of blade  
\*\* Thick-soled (Rock Boots)

## POWER PLANA

code: 410007

- BUNGEE STRAP
- FULL SHAPE FOOT POCKET
- MADE IN NATURAL RUBBER
- NEGATIVE BUOYANCY



### TECHNICAL FEATURES

Sizes	S	R	XL	XXL
Fit	37/41	41/44	44/48	44/50**
Blade*	29 cm / 11.4 in	29 cm / 11.4 in	29,5 cm / 11.6 in	29,5 cm / 11.6 in

## BUNGEE STRAP

code: 415363 (PAIR)

- SMART ALTERNATIVE TO STEEL SPRING STRAPS
- 3 SIZES: XS/S - R - XL
- 5 COLOR OPTIONS: BK-WH-BL-YL-LM
- 2 EXTENSIONS FOR A BETTER FIT
- ERGONOMIC HEEL COVER
- WIDE LOOP TO BE USED EVEN WITH THICK GLOVES



BK



WH



BL



YL



LM

## ABS PLUS BUCKLE

code: 415337

- USER FRIENDLY BUCKLE SYSTEM
- EASY DONNING AND DOFFING WITH THICK GLOVES
- CAN BE MOUNTED ON ALL MARES OPEN HEEL FINNS



## FIN STRAP

code: 415120

- UNIVERSAL FIN STRAP FOR OPEN HEEL FINNS
- WIDTH: 30 mm/1.2 in - LENGTH: 460 mm/18.1 in
- HIGH QUALITY VULCANIZED RUBBER MATERIAL



Finns	Avanti Pure	Avanti HC Pro	Avanti HC	Excite Pro	Excite	X-stream	Avanti Excel	Volo Power	Volo Race	Avanti Quattro +	Avanti Quattro Power	Avanti Superchannel OH	Avanti Superchannel FF	Avanti Tre	Power Plana	
Code	410027	410347	410346	410026	410025	410019	410316	410008	410313	410003	410301	410012	410317	410302	410007	
Sizes	SM - ML - LXL	36/37 38/39 40/41 42/43 44/45 46/47	36/37 38/39 40/41 42/43 44/45 46/47	XS - S - R - XL	XS - S - R - XL	XS - S - R - XL	34/35 36/37 38/39 40/41 42/43 44/45 46/47	S - R - XL	36/37 38/39 40/41 42/43 44/45 46/47	S - R - XL	40/41 42/43 44/45 46/47	S - R - XL	36/37 38/39 40/41 42/43 44/45 46/47	36/37 38/39 40/41 42/43 44/45 46/47	S - R - XL	
Colors	YL BL WH	BKY BKB BKR WHB WHP	YL BL GR	GR	YL BL	YL BL RD TBK WH JPK	YL BL SI	YL BL SI	YL BL BGR	YL BL BK WH LM FL	BK	YL BL BK	YL BL RD WH	YL BL BK	BK	
OPB - Optimized Pivoting Blade				■	■			■	■							
Channel thrust	■	■	■	■	■	■	■	■	■	■	■	■	■	■	■	
Tri-material construction		■				■	■									
Thermoplastic rubber/Technopolymers				■	■	■	■	■	■							
Thermoplastic rubber/Tecralene®	■	■	■							■	■	■	■	■		
Natural rubber															■	
Blade*: Open heel (size R or ML) Full foot (size 42/43)	Length	cm	32	38	38	40	37	33	37	37	38	45,5	37	35,5	36	27,5
		in	12.6	15	15	15.7	14.6	13	14.6	14.6	15	17.9	14.6	14	14.2	10.8
Thrust Area	cm <sup>2</sup>	550	750	750	800	750	560	700	680	780	960	730	650	680	600	
	in <sup>2</sup>	85.2	116.2	116.2	124.0	116.3	86.8	108.5	105.4	120.9	148.8	113.1	100.7	105.4	93	
Weight one fin without buckles (size R or ML - 42/43)	kg	0,6	0,7	0,7	0,9	0,7	0,6	0,7	0,7	0,9	1	0,9	0,7	0,6	1,3	
	lb	1.4	1.5	1.5	2	1.5	1.3	1.5	1.5	2	2.2	2	1.5	1.3	2.9	

\* From end of footpocket to end of blade



## CHROMA LIQUIDSKIN

NEW

code: 411061

- BI-LENS LIQUIDSKIN MASK
- DESIGN AND TECHNOLOGY FROM MARES
- FRAME CONSTRUCTED IN ADVANCED MATERIAL WITH A MATT CHROME PLATED, UNIQUE LOOK
- INCREASED OPTICAL CONE AND FIELD OF VISION TOWARDS THE TOP
- QUICK RELEASE LENS SYSTEM: NEW SMART MECHANISM (PATENT PENDING) TO REPLACE LENSES WITHOUT THE USE OF TOOLS



# MASKS & SNORKELS\*

\* Please note that some items are only available while stocks last

### COLOR VARIATIONS



### TECHNICAL FEATURES

Weight (g)	198
------------	-----

### ACCESSORIES

Optical lens (from -1,0 to -7,0 - from +1,5 to +3,0)	411193
--	--------

### BUCKLE



### DETAILS



Matt chrome frame      Increased upper-lens vision



Quick release lens retainers      Low profile frame for an extended field of vision

## X-VISION ULTRA LIQUIDSKIN

code: 411052

- ULTRA CLEAR SKIRT (CLYLWCYL, CLBLWCBL)
- MIRRORED GOLD LENSE INCREASES VISIBILITY IN CLOUDY WATERS (GOGRKGRK)
- MIRRORED SILVER LENSE REDUCES THE REFLECTION OF SHALLOW WATER OR SANDY SEABED (SIGRKGRK)
- NEW BI-SILICONE SKIRT CONTOURED FOR ENHANCED FIT AND COMFORT
- LOW DRAG DESIGN
- SMALL RIBS AROUND NOSE TO RELIEVE PRESSURE
- FIELD OF VISION 20% WIDER THAN PREVIOUS VERSION
- X-SHAPED BI-SILICONE STRAP



CLEAR LENS



MIRRORED LENS



reddot award  
winner

### COLOR VARIATIONS



CLWHKWHK CLRDKRDK CLGRKGRK CLYLKYLK CLYLWCYL CLBLWCBL



CLBLWBLW CLPKWPKW

### COLOR VARIATIONS MIRRORED



SIGRKGRK GOGRKGRK

### MIRRORED LENSES

Mirrored lenses do not hide the user's eyes, ensuring visual contact when diving.

### MIRRORED SILVER COATING

Reduces the diffuse reflection of shallow waters and sandy seabeds.

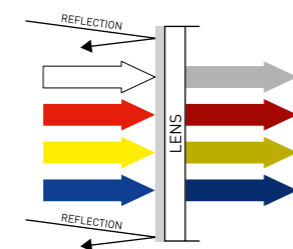

### MIRRORED GOLD COATING

Reduces the dominant blue color and increases contrast and visibility.

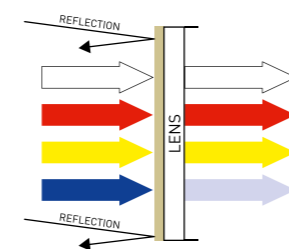

### TECHNICAL FEATURES

Weight (g)	183
------------	-----

### ACCESSORIES

Optical lens (from -1,0 to -7,0 - from +1,5 to +3,0)	411194
--	--------

### BUCKLE

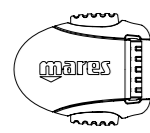

## X-VU LIQUIDSKIN

code: 411033

code: 411041 Sunrise

- BI-SILICONE SKIRT FOR UNMATCHED COMFORT
- SMALL RIBS AROUND NOSE TO RELIEVE PRESSURE
- X-SHAPED BI-SILICONE STRAP
- OPTICAL LENSES AVAILABLE
- SUNRISE VERSION AVAILABLE



## ESSENCE LIQUIDSKIN

code: 411031

- BI-SILICONE SKIRT FOR UNMATCHED COMFORT
- LIGHT AND FOLDABLE, ALSO IDEAL AS SPARE MASK
- AMPLE FIELD OF VISION
- X-SHAPED BI-SILICONE STRAP
- SINGLE LENS DESIGN



### COLOR VARIATIONS



CYLYL CBLBL CRDRD SBKBK WBLWH WPKWH



WBKWH SIHWH

### COLOR VARIATIONS SUNRISE



WRDWH GBKGR WBLWH WPKWH SWHWH WLBW

### TECHNICAL FEATURES

Weight (g)	173
------------	-----

### ACCESSORIES

Optical lens (from -1,0 to -6,0 - from +1,5 to +3,0)	411192
--	--------

### BUCKLE

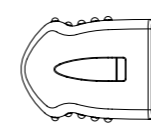

### COLOR VARIATIONS

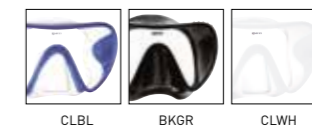

CLBL BKGR CLWH

### TECHNICAL FEATURES

Weight (g)	185
------------	-----

### BUCKLE

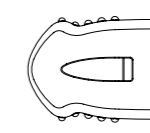



## X-FREE

code: 411060

- OVERMOLDED FRAME AND ANATOMICAL SILICONE SKIRT
- MINIMUM DISTANCE BETWEEN LENS AND EYES
- AMPLE FIELD OF VISION
- LIGHTWEIGHT
- ERGONOMIC MASK STRAP BUCKLES FOR EASY OPERATION
- EMBOSSED GRIP AREA ON THE NOSE FOR PERFECT FIT WITH A NOSE CLIP



### COLOR VARIATIONS



### TECHNICAL FEATURES

Weight (g)	147
------------	-----

### BUCKLE



## I3

code: 411040

code: 411042 Sunrise

- SILICONE SKIRT
- SMALL RIBS AROUND NOSE TO RELIEVE PRESSURE
- GREAT PERIPHERAL VISION
- X-SHAPED SILICONE STRAP
- SUNRISE VERSION AVAILABLE



### COLOR VARIATIONS

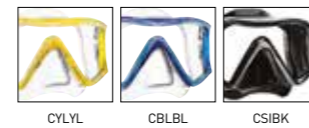

### COLOR VARIATIONS SUNRISE

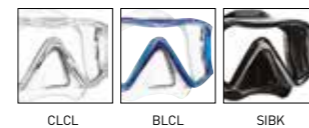

### TECHNICAL FEATURES

Weight (g)	210
------------	-----

### BUCKLE

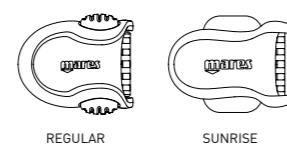

## JUNO

code: 411056

- FRAMELESS MONOLENS MASK
- SILICONE SKIRT
- SAME STYLE AS THE JUPITER BUT WITH A REGULAR SKIRT FIT
- PIVOTING BUCKLE ON SKIRT
- GREAT FIELD OF VISION



### COLOR VARIATIONS



### TECHNICAL FEATURES

Weight (g)	192
------------	-----

### BUCKLE

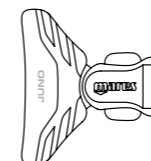

## JUPITER

code: 411057

- FRAMELESS MONOLENS MASK
- SILICONE SKIRT
- SAME STYLE AS THE JUNO BUT WITH AN "XL" SKIRT FIT FOR BIGGER FACES
- PIVOTING BUCKLE ON SKIRT
- GREAT FIELD OF VISION



### COLOR VARIATIONS



### TECHNICAL FEATURES

Weight (g)	194
------------	-----

### BUCKLE

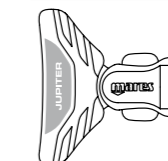

## SEALHOUETTE

code: 411058

- BI-LENS MASK
- SILICONE SKIRT
- REDUCED DISTANCE BETWEEN LENSES AND EYES
- AMPLE FIELD OF VISION
- LIGHTWEIGHT
- SOFT SILICONE BUCKLES
- BUCKLES ON SKIRT



### COLOR VARIATIONS

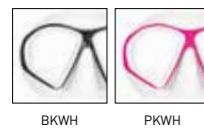

### TECHNICAL FEATURES

Weight (g)	161
------------	-----

### BUCKLE

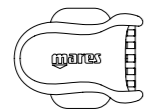

## COMET

code: 411059

- MONOLENS MASK FOR CHILDREN
- SILICONE SKIRT
- AMPLE FIELD OF VISION
- LIGHTWEIGHT
- COMFORTABLE DETACHABLE BUCKLES



### COLOR VARIATIONS

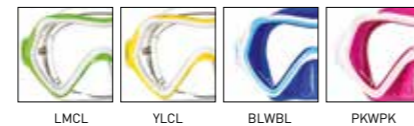

### TECHNICAL FEATURES

Weight (g)	174
------------	-----

### BUCKLE

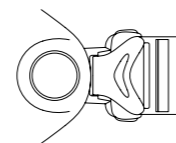

## X-VU

code: 411036

- SILICONE SKIRT
- SMALL RIBS AROUND NOSE TO RELIEVE PRESSURE
- X-SHAPED SILICONE STRAP
- OPTICAL LENSES AVAILABLE



### COLOR VARIATIONS



### TECHNICAL FEATURES

Weight (g)	174
------------	-----

### ACCESSORIES

Optical lens (from -1,0 to -6,0 - from +1,5 to +3,0)	411192
--	--------

### BUCKLE

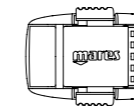

## X-VISION

code: 411053

- ULTRA CLEAR SILICONE
- LOW DRAG DESIGN
- SMALL RIBS AROUND NOSE TO RELIEVE PRESSURE
- FIELD OF VISION 20% WIDER THAN PREVIOUS VERSION
- X-SHAPED SILICONE STRAP
- OPTICAL LENSES AVAILABLE



### COLOR VARIATIONS

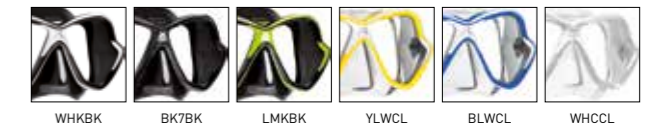

### TECHNICAL FEATURES

Weight (g)	189
------------	-----

### ACCESSORIES

Optical lens (from -1,0 to -7,0 - from +1,5 to +3,0)	411194
--	--------

### BUCKLE

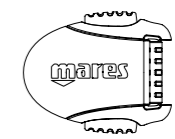

## X-VISION MID

code: 411024

- SILICONE SKIRT
- MEDIUM SIZED
- WIDE VIEWING ANGLE
- X-SHAPED SILICONE STRAP
- OPTICAL LENSES AVAILABLE



### COLOR VARIATIONS



CLCBL BKBK CLWLB CLBGR

### TECHNICAL FEATURES

Weight (g)	189
------------	-----

### ACCESSORIES

Optical lens (from -1,0 to -6,0)	411187
Optical lens (from +1,5 to +3,0)	411186

### BUCKLE

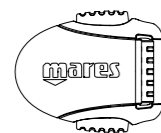

## ONE VISION

code: 411046

code: 411047 Sunrise

- SILICONE SKIRT
- LOW DRAG DESIGN
- SMALL RIBS AROUND NOSE TO RELIEVE PRESSURE
- SINGLE LENS DESIGN
- X-SHAPED SILICONE STRAP
- SUNRISE VERSION AVAILABLE



### COLOR VARIATIONS



WHKBK RDKBK BK7BK WSICL WYLCL WBLCL

### COLOR VARIATIONS SUNRISE



BK7BK\* RDKBK WBLCL WSIWH\*

### TECHNICAL FEATURES

Weight (g)	200
------------	-----

### BUCKLE



\* Only available in some countries via drop shipment

## TANA

code: 411055

- SILICONE SKIRT
- SOFT TOUCH INSERTS ON THE FRAME FOR GRIP
- LIGHTWEIGHT
- SIDE GUSSETS AT THE NOSE TO FACILITATE EQUALIZING



### COLOR VARIATIONS



YLKCL BLKCL RDKBK PKWWH PUWWH BLWCL



LBWWH

### TECHNICAL FEATURES

Weight (g)	155
------------	-----

### BUCKLE

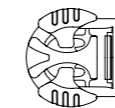

## TROPICAL

code: 411246

- FRAMELESS SILICONE MASK
- ULTRA COMFORTABLE SKIRT
- BUCKLES WITH SOFT SILICONE BUTTONS



### COLOR VARIATIONS



YL BL RD WH PK GN

### TECHNICAL FEATURES

Weight (g)	181
------------	-----

### BUCKLE



## OPERA

code: 411019

- SILICONE SKIRT
- STURDY AND DURABLE CONSTRUCTION
- OVAL SHAPED SILICONE STRAP
- OPTICAL LENSES AVAILABLE



### COLOR VARIATIONS



### TECHNICAL FEATURES

Weight (g)	184
------------	-----

### ACCESSORIES

Optical lens (from -1,0 to -6,0)	411182
----------------------------------	--------

### BUCKLE

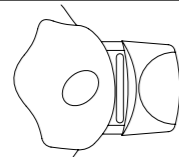

## MASK STRAP LiquidSkin

code: 415115 WHITE

code: 415116 BLACK

- MASK STRAP FOR LIQUIDSKIN MASKS
- WIDTH: 14 mm/0.55 in - LENGTH: 580 mm/22.8 in
- BI-SILICONE MATERIAL



## MASK STRAP

code: 415105 CLEAR

code: 415106 BLACK

- UNIVERSAL MASK STRAP
- WIDTH: 14 mm/0.55 in - LENGTH: 560 mm/22.0 in
- SILICONE MATERIAL



## STRAP COVER

code: 412901

code: 412902 She Dives

- ONE SIZE FITS ALL
- SOFT NEOPRENE MASK STRAP COVER
- HELPS TO KEEP THE MASK STRAP IN PLACE
- HIGH COMFORT
- TANGLE-FREE DIVE



## ANTIFOG

code: 415101

- GEL TO PREVENT MASK LENSES FROM FOGGING UP
- OPEN/CLOSE CAP WITH BRUSH
- MADE IN COMPLIANCE WITH LATEST REGULATIONS
- 60 ml



Mask	Chroma LiquidSkin	X-vision Ultra LiquidSkin		X-vu LiquidSkin		Essence LiquidSkin	X- Free	i3		Juno	Jupiter
		Regular	Mirrored	Regular	Sunrise			Regular	Sunrise		
Code	411061	411052	411052	411033	411041	411031	411060	411040	411042	411056	411057
Colors	<ul style="list-style-type: none"> <li>■ WHBK</li> <li>■ RDBK</li> <li>■ BLWH</li> <li>■ CYLCL</li> <li>■ CBLCL</li> </ul>	<ul style="list-style-type: none"> <li>■ CLWHKWHK</li> <li>■ CLRDKRDK</li> <li>■ CLGRKGRK</li> <li>■ CLYLKYLK</li> <li>■ CLYLWCYL</li> <li>■ CLBLWCBL</li> <li>■ CLBLWBLW</li> <li>■ CLPKWPKW</li> </ul>	<ul style="list-style-type: none"> <li>■ SIGRKGRK</li> <li>■ GOGRKGRK</li> </ul>	<ul style="list-style-type: none"> <li>■ CYLCL</li> <li>■ CBLBL</li> <li>■ CRDRD</li> <li>■ SBKKB</li> <li>■ WBLWH</li> <li>■ WPKWH</li> <li>■ WBKWH</li> <li>■ SWHWH</li> </ul>	<ul style="list-style-type: none"> <li>■ WRDWH</li> <li>■ SBKGR</li> <li>■ WBLWH</li> <li>■ WPKWH</li> <li>■ SWHWH</li> <li>■ WLBWH</li> </ul>	<ul style="list-style-type: none"> <li>■ CLBL</li> <li>■ BKGR</li> <li>■ CLWH</li> </ul>	<ul style="list-style-type: none"> <li>■ WHBK</li> <li>■ LMBK</li> <li>■ YLBK</li> <li>■ BLWH</li> <li>■ PKWH</li> </ul>	<ul style="list-style-type: none"> <li>■ CYLCL</li> <li>■ CBLBL</li> <li>■ CSIBK</li> </ul>	<ul style="list-style-type: none"> <li>■ CLCL</li> <li>■ BLCL</li> <li>■ SIBK</li> </ul>	<ul style="list-style-type: none"> <li>■ WHBK</li> <li>■ RDBK</li> <li>■ LMBK</li> <li>■ WHBL</li> <li>■ RDWH</li> <li>■ BLWH</li> <li>■ WHCL</li> <li>■ PKCL</li> </ul>	<ul style="list-style-type: none"> <li>■ WHBK</li> <li>■ BLBK</li> <li>■ BKWH</li> <li>■ RDWH</li> </ul>
Weight (g)	198	183		173			147	210		192	194
LiquidSkin	■	■		■		■					
Sunrise				■				■			
Monolens						■		■		■	■
Bitens	■	■		■			■				
Tri-comfort	■	■		■				■			
Optical lenses	■	■		■							
Optical Lens (optionals)	Code 411193 from -1 to -7 Code 411193 from +1.5 to +3	Code 411194 from -1 to -7 Code 411194 from +1.5 to +3	NO	Code 411192 from -1 to -6,0 Code 411192 from +1.5 to +3		NO	NO	NO		NO	NO



Mask	Sealhouette	Comet	X-vu	X-vision	X-vision Mid	One Vision		Tana	Tropical	Opera
						Regular	Sunrise			
Code	411058	411059	411036	411053	411024	411046	411047	411055	411246	411019
Colors	<ul style="list-style-type: none"> <li>■ YLBK</li> <li>■ RDBK</li> <li>■ LMBK</li> <li>■ WHBK</li> <li>■ WHBL</li> <li>■ RDWH</li> <li>■ BKWH</li> <li>■ PKWH</li> </ul>	<ul style="list-style-type: none"> <li>■ LMCL</li> <li>■ YLCL</li> <li>■ BLWBL</li> <li>■ PKWPK</li> </ul>	<ul style="list-style-type: none"> <li>■ YLCL</li> <li>■ BLCL</li> <li>■ RDCL</li> <li>■ BKBK</li> <li>■ BGRCL</li> </ul>	<ul style="list-style-type: none"> <li>■ WHKBK</li> <li>■ BK7BK</li> <li>■ LMBK</li> <li>■ YLWCL</li> <li>■ BLWCL</li> <li>■ WHCCL</li> </ul>	<ul style="list-style-type: none"> <li>■ CLCBL</li> <li>■ BKBL</li> <li>■ CLWLB</li> <li>■ CLBGR</li> </ul>	<ul style="list-style-type: none"> <li>■ WHKBK</li> <li>■ RDKBK</li> <li>■ BK7BK</li> <li>■ WSLCL</li> <li>■ WYLCL</li> <li>■ WBLCL</li> </ul>	<ul style="list-style-type: none"> <li>■ BK7BK*</li> <li>■ RDKBK</li> <li>■ WBLCL</li> <li>■ WSIWH*</li> </ul>	<ul style="list-style-type: none"> <li>■ YLCL</li> <li>■ BLKCL</li> <li>■ RDKBK</li> <li>■ PKWHH</li> <li>■ PUWWH</li> <li>■ BLWCL</li> <li>■ LBWWH</li> </ul>	<ul style="list-style-type: none"> <li>■ YL</li> <li>■ BL</li> <li>■ RD</li> <li>■ WH</li> <li>■ PK</li> <li>■ GN</li> </ul>	<ul style="list-style-type: none"> <li>■ RYLCL</li> <li>■ RBLCL</li> <li>■ TBKKB</li> </ul>
Weight (g)	161	174	174	189	183	200		155	181	184
Sunrise						■				
Monolens		■				■			■	
Bitens	■		■	■	■			■		■
Tri-comfort			■	■	■	■				
Optical lenses			■	■						■
Optical Lens (optionals)	NO	NO	Code 411192 from -1 to -6,0 Code 411192 from +1.5 to +3	Code 411194 from -1 to -7 Code 411194 from +1.5 to +3	Code 411187 from -1 to -6,0 Code 411186 from +1.5 to +3	NO		NO	NO	Code 411182 from -1 to -6,0 NO

\* Only available in some countries via drop shipment

## REBEL DRY

code: 411487

- 100% DRY TOP
- SLIDING SNORKEL KEEPER
- CORRUGATED SILICONE HOSE AND MOUTHPIECE
- EXHAUST VALVE
- SUITABLE FOR DIVING OR EXTENDED SNORKELING SESSIONS
- UNPARALLELED BREATHING COMFORT DUE TO THE INCREASED INTERNAL VOLUME OF THE BOTTOM HOUSING



## REBEL SPLASH

code: 411488

- SEMIDRY TOP WITH ANTI-SPLASH
- SLIDING SNORKEL KEEPER
- CORRUGATED SILICONE HOSE AND MOUTHPIECE
- EXHAUST VALVE
- SUITABLE FOR DIVING OR EXTENDED SNORKELING SESSIONS
- UNPARALLELED BREATHING COMFORT DUE TO THE INCREASED INTERNAL VOLUME OF THE BOTTOM HOUSING



### COLOR VARIATIONS



## REBEL FLEX

code: 411489

- SLIDING SNORKEL KEEPER
- CORRUGATED SILICONE HOSE AND MOUTHPIECE
- EXHAUST VALVE
- SUITABLE FOR DIVING OR EXTENDED SNORKELING SESSIONS
- UNPARALLELED BREATHING COMFORT DUE TO THE INCREASED INTERNAL VOLUME OF THE BOTTOM HOUSING



### COLOR VARIATIONS

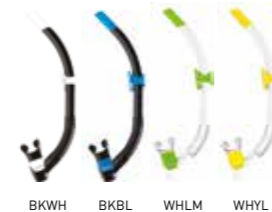

### COLOR VARIATIONS

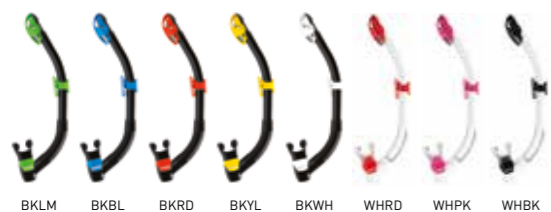

## ERGO DRY

code: 411481

- 100% DRY TOP
- SLIDING SWIVEL SNORKEL KEEPER
- CORRUGATED SILICONE HOSE AND MOUTHPIECE
- EXHAUST VALVE
- SUITABLE FOR DIVING OR EXTENDED SNORKELING SESSIONS



### COLOR VARIATIONS



## ERGO SPLASH

code: 411480

- SEMIDRY TOP WITH ANTI-SPLASH
- SLIDING SWIVEL SNORKEL KEEPER
- CORRUGATED SILICONE HOSE AND MOUTHPIECE
- EXHAUST VALVE
- SUITABLE FOR DIVING OR EXTENDED SNORKELING SESSIONS



### COLOR VARIATIONS



## ERGO FLEX

code: 411482

- SLIDING SWIVEL SNORKEL KEEPER
- CORRUGATED SILICONE HOSE AND MOUTHPIECE
- EXHAUST VALVE
- SUITABLE FOR DIVING OR EXTENDED SNORKELING SESSIONS



### COLOR VARIATIONS



## SNORKEL @

code: 411479

- ERGONOMIC SHAPE
- ROLL UP, COMPACT DESIGN
- FITS IN A BCD POCKET OR CAN BE ATTACHED TO A BC
- ALL SILICONE DESIGN FOR FLEXIBILITY AND DURABILITY
- TUBE TOP DESIGN MADE TO PREVENT WATER ENTRY WHILE SNORKELING
- IDEAL FOR TRAVELLING



### COLOR VARIATIONS



## PRO FLEX

code: 411460

- BI-MATERIAL SOFT CONSTRUCTION
- CURVED, ERGONOMIC STRUCTURE
- NO AIRFLOW INTERRUPTIONS TO REDUCE NOISE AND VIBRATIONS
- SLIDING KEEPER
- SILICONE MOUTHPIECE FOR EXTENDED USE



## PLUTO

code: 411486

- 100% DRY TOP SNORKEL DEDICATED TO JUNIORS
- SLIDING SNORKEL KEEPER
- SILICONE MOUTHPIECE
- EXHAUST VALVE
- WHISTLE ON BOTTOM AS SAFETY DEVICE



### COLOR VARIATIONS

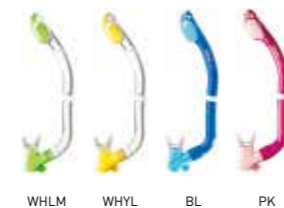

Snorkel	Rebel Dry	Rebel Splash	Rebel Flex	Ergo Dry	Ergo Splash	Ergo Flex	Snorkel @	Pro Flex	Pluto
Code	411487	411488	411489	411481	411480	411482	411479	411460	411486
Colors	<ul style="list-style-type: none"> <li>■ BKLM</li> <li>■ BKBL</li> <li>■ BKRD</li> <li>■ BKYL</li> <li>■ BKWH</li> <li>■ WHRD</li> <li>■ WHPK</li> <li>■ WHBK</li> </ul>	<ul style="list-style-type: none"> <li>■ BKWH</li> <li>■ BKPK</li> <li>■ WHRD</li> <li>■ WHBK</li> </ul>	<ul style="list-style-type: none"> <li>■ BKWH</li> <li>■ BKBL</li> <li>■ WHLM</li> <li>■ WHYL</li> </ul>	<ul style="list-style-type: none"> <li>■ RYL</li> <li>■ RBL</li> <li>■ BK</li> <li>■ CL</li> <li>■ JPK</li> <li>■ WH</li> <li>■ BWH</li> <li>■ BRD</li> <li>■ BYL</li> <li>■ BLM</li> </ul>	<ul style="list-style-type: none"> <li>■ RYL</li> <li>■ RBL</li> <li>■ BK</li> <li>■ CL</li> </ul>	<ul style="list-style-type: none"> <li>■ RYL</li> <li>■ RBL</li> <li>■ BK</li> <li>■ RD</li> </ul>	<ul style="list-style-type: none"> <li>■ BK</li> <li>■ WH</li> </ul>	<ul style="list-style-type: none"> <li>■ BK</li> </ul>	<ul style="list-style-type: none"> <li>■ WHLM</li> <li>■ WHYL</li> <li>■ BL</li> <li>■ PK</li> </ul>
Dry top	■			■					■
Purge valve	■	■	■	■	■	■			■



### EOS 20RZ W/ LOCK

**NEW**

code: 415688

- 2300 LUMENS
- MAGNETIC ADJUSTABLE FOCUS
- 100 MINUTES OF BURN TIME (MAX POWER)
- IN-HOUSE RECHARGEABLE BATTERY
- USB RECHARGEABLE CABLE
- LED CHARGE INDICATOR
- WIDE LIGHT BEAM
- MAGNETIC MULTIFUNCTION SWITCH WITH SAFETY LOCK
- FOUR OPTIONS: ON, LOW, FLASH, OFF
- ONE-HAND USE
- TUBULAR HANDLE
- ADJUSTABLE WRIST STRAP
- PADDED CASE WITH ZIP

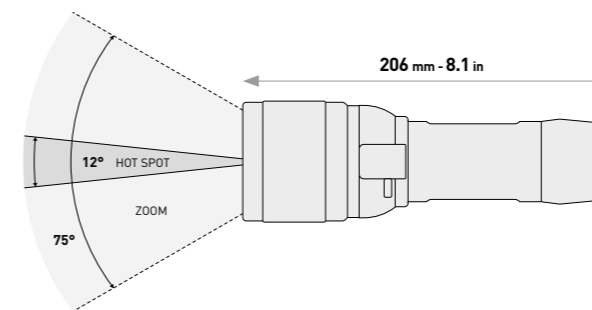

#### TECHNICAL FEATURES

<b>Bulb</b>	3 Cree XP-L LED Chip		
<b>Switch mode</b>	High	Low	Flash/SOS
<b>Led lumens (25°)</b>	2300	690	/
<b>Burn time (min)</b>	100	180	310
<b>Color temperature (k)</b>	5700-7800		
<b>Light beam (1m distance)</b>	Hot Spot (12°)	Corona (75°)	
<b>(Mm/in)</b>	230 / 9.0	1550 / 61	
<b>Rechargeable batteries (li-ion)</b>	1x ICR26800		
<b>Time to charge</b>	7h (5V1A adapter) - 14h (PC 500mA)		
<b>Total length (mm/in)</b>	206 / 8.1		
<b>Head diameter (mm/in)</b>	62 / 2.4		
<b>Body diameter (mm/in)</b>	37 / 1.5		
<b>Weight with batteries (gr/oz)</b>	594 / 20.9		
<b>Max operating depth (m/feet)</b>	120 / 393		

### EOS 15RZ

**NEW**

code: 415689

- 1504 LUMENS
- MAGNETIC ADJUSTABLE FOCUS
- 125 MINUTES OF BURN TIME (MAX POWER)
- IN-HOUSE RECHARGEABLE BATTERY
- USB RECHARGEABLE CABLE
- LED CHARGE INDICATOR
- WIDE LIGHT BEAM
- MAGNETIC MULTIFUNCTION SWITCH WITH SAFETY LOCK
- FOUR OPTIONS: ON, LOW, FLASH, OFF
- ONE-HAND USE
- TUBULAR HANDLE
- ADJUSTABLE WRIST STRAP
- PADDED CASE WITH ZIP

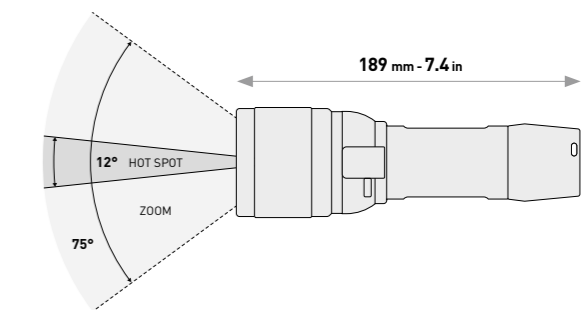

#### TECHNICAL FEATURES

<b>Bulb</b>	3 Cree XP-G2 LED Chip		
<b>Switch mode</b>	High	Low	Flash/SOS
<b>Led lumens (25°)</b>	1504	500	/
<b>Burn time (min)</b>	125	185	180
<b>Color temperature (k)</b>	5800 ÷ 7300		
<b>Light beam (1m distance)</b>	Hot Spot (12°)	Corona (75°)	
<b>(Mm/in)</b>	230 / 9.0	1550 / 61	
<b>Rechargeable batteries (li-ion)</b>	1x ICR26650		
<b>Time to charge</b>	6 h (5V1A adapter) - 12 h (PC 500mA)		
<b>Total length (mm/in)</b>	189 / 7.4		
<b>Head diameter (mm/in)</b>	62 / 2.4		
<b>Body diameter (mm/in)</b>	37 / 1.5		
<b>Weight with batteries (gr/oz)</b>	553 / 19.5		
<b>Max operating depth (m/feet)</b>	120 / 393		

# ACCESSORIES\*

\* Please note that some items are only available while stocks last

## EOS 10RZ

**NEW**

code: 415690

- 1010 LUMENS
- MAGNETIC ADJUSTABLE FOCUS
- 135 MINUTES OF BURN TIME (MAX POWER)
- IN-HOUSE RECHARGEABLE BATTERY
- USB RECHARGEABLE CABLE
- LED CHARGE INDICATOR
- WIDE LIGHT BEAM
- MAGNETIC MULTIFUNCTION SWITCH WITH SAFETY LOCK
- FOUR OPTIONS: ON, LOW, FLASH, OFF
- ONE-HAND USE
- TUBULAR HANDLE
- ADJUSTABLE WRIST STRAP
- PADDED CASE WITH ZIP

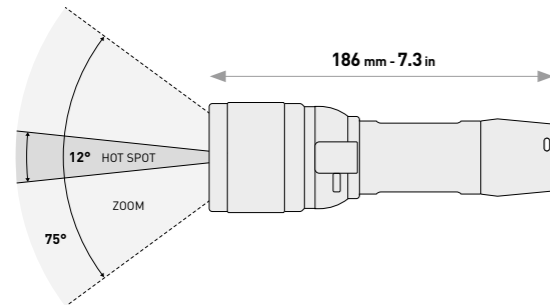

### TECHNICAL FEATURES

<b>Bulb</b>	1 Cree XM-L2 LED Chip		
<b>Switch mode</b>	High	Low	Flash/SOS
<b>Led lumens (25°)</b>	1010	365	/
<b>Burn time (min)</b>	135	255	240
<b>Color temperature (k)</b>	5800 ÷ 7300		
<b>Light beam (1m distance)</b>	Hot Spot (12°)	Corona (75°)	
<b>(Mm/in)</b>	220 / 8.6	1550 / 61	
<b>Rechargeable batteries (li-ion)</b>	1x ICR26650		
<b>Time to charge</b>	6 h (5V1A adapter) - 12 h (PC 500mA)		
<b>Total length (mm/in)</b>	186 / 7.3		
<b>Head diameter (mm/in)</b>	57 / 2.2		
<b>Body diameter (mm/in)</b>	37 / 1.5		
<b>Weight with batteries (gr/oz)</b>	537 / 18.8		
<b>Max operating depth (m/feet)</b>	120 / 393		

## EOS 5RZ

**NEW**

code: 415691

- 503 LUMENS
- ADJUSTABLE FOCUS
- 105 MINUTES OF BURN TIME (MAX POWER)
- IN-HOUSE RECHARGEABLE BATTERY
- USB RECHARGEABLE CABLE
- LED CHARGE INDICATOR
- WIDE LIGHT BEAM
- MAGNETIC MULTIFUNCTION SWITCH WITH SAFETY LOCK
- FOUR OPTIONS: ON, LOW, FLASH, OFF
- ONE-HAND USE
- TUBULAR HANDLE
- ADJUSTABLE WRIST STRAP
- PADDED CASE WITH ZIP

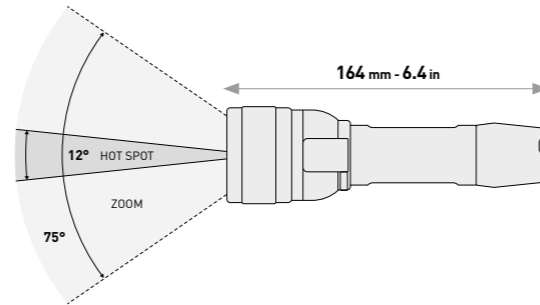

### TECHNICAL FEATURES

<b>Bulb</b>	1 Cree XP-G2 LED Chip		
<b>Switch mode</b>	High	Low	Flash/SOS
<b>Led lumens (25°)</b>	503	165	/
<b>Burn time (min)</b>	105	270	220
<b>Color temperature (k)</b>	5800 ÷ 7300		
<b>Light beam (1m distance)</b>	Hot Spot (12°)	Corona (75°)	
<b>(Mm/in)</b>	220 / 8.6	1550 / 61	
<b>Rechargeable batteries (li-ion)</b>	1x ICR18650		
<b>Time to charge</b>	4 h 30' (5V1A adapter) - 6 h (PC 500mA)		
<b>Total length (mm/in)</b>	164 / 6.4		
<b>Head diameter (mm/in)</b>	43 / 1.7		
<b>Body diameter (mm/in)</b>	29 / 1.1		
<b>Weight with batteries (gr/oz)</b>	280 / 9.8		
<b>Max operating depth (m/feet)</b>	120 / 393		

## EOS 3RZ

**NEW**

code: 415692

- 320 LUMENS
- ADJUSTABLE FOCUS
- 55 MINUTES OF BURN TIME (MAX POWER)
- IN-HOUSE RECHARGEABLE BATTERY
- USB RECHARGEABLE CABLE
- LED CHARGE INDICATOR
- WIDE LIGHT BEAM
- MAGNETIC MULTIFUNCTION SWITCH WITH SAFETY LOCK
- FOUR OPTIONS: ON, LOW, FLASH, OFF
- ONE-HAND USE
- TUBULAR HANDLE
- ADJUSTABLE WRIST STRAP
- PADDED CASE WITH ZIP

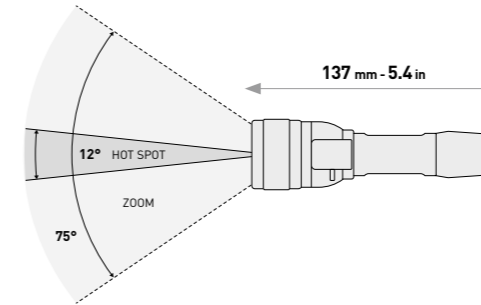

### TECHNICAL FEATURES

<b>Bulb</b>	1 Cree XPE LED Chip		
<b>Switch mode</b>	High	Low	Flash/SOS
<b>Led lumens (25°)</b>	320	105	/
<b>Burn time (min)</b>	55	120	130
<b>Color temperature (k)</b>	6700 ÷ 7800		
<b>Light beam (1m distance)</b>	Hot Spot (12°)	Corona (75°)	
<b>(Mm/in)</b>	220 / 8.6	1550 / 61	
<b>Rechargeable batteries (li-ion)</b>	1x ICR14500		
<b>Time to charge</b>	3 h (5V1A adapter) - 3 h (PC 500mA)		
<b>Total length (mm/in)</b>	137 / 5.4		
<b>Head diameter (mm/in)</b>	35 / 1.3		
<b>Body diameter (mm/in)</b>	23 / 0.9		
<b>Weight with batteries (gr/oz)</b>	152 / 5.3		
<b>Max operating depth (m/feet)</b>	120 / 393		

## EOS STROBE

**NEW**

code: 415693

- 450 LUMENS
- 360° HIGH VISIBILITY
- 5/25 HOURS OF BURN TIME
- IN-HOUSE RECHARGEABLE BATTERY
- USB RECHARGEABLE CABLE
- LED CHARGE INDICATOR
- MAGNETIC, ROTATIONAL SWITCH
- TWO OPERATING MODES: ON, STROBE
- ANODIZED ALUMINUM HOUSING
- ADJUSTABLE STRAP
- PADDED CASE WITH ZIP



### TECHNICAL FEATURES

<b>Bulb</b>	1 Cree XPE LED Chip	
<b>Switch mode</b>	High	Flash/SOS
<b>Led lumens (25°)</b>	450	/
<b>Burn time (min)</b>	300	1500
<b>Color temperature (k)</b>	5800 ÷ 7300	
<b>Light beam (1m distance)</b>	Diffused light	
<b>Flash Rate (p/min)</b>	120	
<b>Rechargeable batteries (li-ion)</b>	1x ICR26650	
<b>Time to charge</b>	6 h (5V1A adapter) - 12 h (PC 500mA)	
<b>Total length (mm/in)</b>	170 / 6.6	
<b>Head diameter (mm/in)</b>	39 / 1.6	
<b>Body diameter (mm/in)</b>	34 / 1.4	
<b>Weight with batteries (gr/oz)</b>	245 / 8.6	
<b>Max operating depth (m/feet)</b>	100 / 328	



## EOS 10RW

**NEW**

code: 415686

- CREE LED 1000 LUMENS
- WIDE LIGHT BEAM
- EXCELLENT FOR VIDEO AND PHOTOGRAPHY
- VISUAL BATTERY INDICATOR
- MULTIFUNCTION SWITCH
- FOUR OPTIONS: ON, LOW, SOS, OFF
- VERY COMPACT AND LIGHTWEIGHT
- IN-HOUSE RECHARGEABLE BATTERY
- USB CHARGER CABLE
- LED CHARGE INDICATOR
- ADJUSTABLE WRIST STRAP
- PADDED CASE WITH ZIP



## EOS 10R

**NEW**

code: 415687

- CREE LED 1000 LUMENS
- POWERFUL LIGHT BEAM
- VISUAL BATTERY INDICATOR
- MULTIFUNCTION SWITCH
- FOUR OPTIONS: ON, LOW, SOS, OFF
- HANDY AND COMPACT
- LED CHARGE INDICATOR
- IN-HOUSE RECHARGEABLE BATTERY
- USB CHARGER CABLE
- ADJUSTABLE WRIST STRAP
- PADDED CASE WITH ZIP



### TECHNICAL FEATURES

Bulb	XM-L2		
	High	Low	Flash/SOS
Switch mode	High	Low	Flash/SOS
Led lumens (25°)	1000	500	/
Burn time (min)	90	150	240
Color temperature (k)	5800 ± 7300		
Light beam (1m distance)	Wide Spot (120°)		
(Mm/in)	2500 / 98.4		
Rechargeable batteries (li-ion)	1x ICR18650		
Time to charge	300min		
Total length (mm/in)	148.1 / 5.8		
Head diameter (mm/in)	28 / 1.1		
Body diameter (mm/in)	26 / 1.0		
Weight with batteries (gr/oz)	178 / 6.3		
Max operating depth (m/feet)	100 / 328		

### TECHNICAL FEATURES

Bulb	XM-L2		
	High	Low	Flash/SOS
Switch mode	High	Low	Flash/SOS
Led lumens (25°)	1000	500	/
Burn time (min)	90	150	240
Color temperature (k)	5800 ± 7300		
Light beam (1m distance)	Hot Spot (12°)		
(Mm/in)	220 / 8.6		
Rechargeable batteries (li-ion)	1x ICR18650		
Time to charge	300min		
Total length (mm/in)	158.7 / 6.2		
Head diameter (mm/in)	28 / 1.1		
Body diameter (mm/in)	26 / 1.0		
Weight with batteries (gr/oz)	188.5 / 6.8		
Max operating depth (m/feet)	100 / 328		

## TORCH ADAPTER

code: 415179

- TURN THE TORCH INTO A VIDEO LIGHT
- DESIGNED FOR FLEXIBLE ARM
- A QUICK, EASY AND RELIABLE SOLUTION
- 3 SIZES (S/21 mm - M/27mm - L/34 mm)
- STAINLESS STEEL WITH RUBBER PROTECTION



## SOFT GOODMAN HANDLE

code: 415180

- ADJUSTABLE HAND STRAP TO BE USED EVEN WITH THICK GLOVES
- SAFETY WRIST STRAP FOR A PERFECT FIT
- DOUBLE ADJUSTABLE VELCRO STRAPS
- CAN BE USED WITH ALL EOS LIGHTS
- RELIABLE AND STURDY MATERIAL
- ADDITIONAL D-RING TO SECURE THE TORCH



## EOS 10RW - VIDEO SET

**NEW**

code: 415685

- COMPLETE SET FOR VIDEO MAKING AND PHOTOGRAPHY
- COMPACT AND LIGHTWEIGHT
- 2 EOS 10RW TORCHES
- USB CHARGER CABLES
- ALUMINUM TRAY FOR ATTACHING VIDEO CAMERA
- FLEXIBLE ARMS WITH CONNECTIONS FOR EOS 10RW
- DEDICATED PADDED CASE WITH ZIP
- CAMERA NOT INCLUDED



## MARKER BEAM

code: 415711

- FLASHING LIGHT STICK
- SAFETY LEASH WITH STOP
- LR 44 BATTERIES



## CRUISE BACKPACK PRO **NEW**

code: 415464

- TELESCOPING HANDLE
- LARGE STURDY WHEELS
- EXTERNAL FIN POCKETS WITH DRAINAGE SYSTEM
- ADJUSTABLE EXTERNAL COMPRESSION STRAPS
- BICOLOR, ULTRALIGHT BUCKLES
- AIR MESH HANDLE
- PADDED SHOULDER STRAPS
- INTEGRATED FRONT POCKETS WITH ZIP
- SIDE HANDLES
- A.T.O. - AIR TRAVEL OPTIMIZED



### TECHNICAL FEATURES

Dimensions (LxWxH)	Unit Net Weight	Volume
47x32x81 cm / 18.5"x12.5"x32"	5 kg / 11 lb	128 L / 7811 cu.in.

## CRUISE BACKPACK **NEW**

code: 415465

- TELESCOPING HANDLE
- LARGE STURDY WHEELS
- EXTERNAL FIN POCKETS WITH DRAINAGE SYSTEM
- ADJUSTABLE EXTERNAL COMPRESSION STRAPS
- BICOLOR, ULTRALIGHT BUCKLES
- AIR MESH HANDLE
- PADDED SHOULDER STRAPS
- INTEGRATED FRONT POCKETS WITH ZIP
- SIDE HANDLES
- A.T.O. - AIR TRAVEL OPTIMIZED



### TECHNICAL FEATURES

Dimensions (LxWxH)	Unit Net Weight	Volume
40x31x80 cm / 16"x12"x31.5"	4,4 kg / 9.7 lb	100 L / 6071 cu.in.

## CRUISE BACKPACK ROLLER **NEW**

code: 415466

- EASY TO FOLD AND STOW
- LARGE STURDY WHEELS
- EXTERNAL FIN POCKETS WITH DRAINAGE SYSTEM
- ADJUSTABLE EXTERNAL COMPRESSION STRAPS
- BICOLOR, ULTRALIGHT BUCKLES
- AIR MESH HANDLE
- PADDED SHOULDER STRAPS
- INTEGRATED FRONT POCKETS
- LIGHTWEIGHT
- A.T.O. - AIR TRAVEL OPTIMIZED



### TECHNICAL FEATURES

Dimensions (LxWxH)	Unit Net Weight	Volume
47x32x81 cm / 18.5"x12.5"x32"	3 kg / 6.6 lb	128 L / 7811 cu.in.

## CRUISE BUDDY **NEW**

code: 415467

- TELESCOPING HANDLE
- WIDE WHEEL BASE FOR STABILITY
- ADJUSTABLE EXTERNAL COMPRESSION STRAPS
- TWO AIR MESH HANDLES
- INTEGRATED FRONT POCKETS WITH ZIPPERS
- ADJUSTABLE INTERNAL TIE-DOWN STRAPS
- BICOLOR, ULTRALIGHT BUCKLES
- BUSINESS CARD WINDOWS
- LIGHTWEIGHT
- A.T.O. - AIR TRAVEL OPTIMIZED



### TECHNICAL FEATURES

Dimensions (LxWxH)	Unit Net Weight	Volume
43x27x75 cm / 17" x 10.5" x 29.5"	3,5 kg / 7.7 lb	87 L / 5309 cu.in.

## CRUISE BACKPACK DRY **NEW**

code: 415540

- ULTRA LIGHTWEIGHT
- COMPLETELY WATERTIGHT
- LARGE INTERNAL VOLUME
- ADJUSTABLE, PADDED AND REMOVABLE SHOULDER STRAPS
- ULTRALIGHT BUCKLES



### TECHNICAL FEATURES

Dimensions (LxWxH)	Unit Net Weight	Volume
42x33x79 cm / 16.5"x13"x31"	1,1 kg / 2.4 lb	108 L / 6590 cu.in.

## CRUISE CAPTAIN **NEW**

code: 415472

- TELESCOPING HANDLE
- WIDE WHEEL PLACEMENT
- EXPANDABLE POCKET WITH ZIPPER
- INTEGRATED FRONT POCKET
- WIDE INTERNAL MESH POCKET
- COMPRESSION STRAPS WITH BICOLOR, ULTRALIGHT BUCKLES
- TOP AND LATERAL SIDE AIR MESH HANDLES
- A.T.O. - AIR TRAVEL OPTIMIZED



### TECHNICAL FEATURES

Dimensions (LxWxH)	Unit Net Weight	Volume
36x22x55cm / 14"x8.5"x22"	2,8 kg / 6.2 lb	42 L / 2563 cu.in.

## CRUISE QUICK PACK

code: 415598

- CAN BE FOLDED INTO A SMALL BAG WITH HANDLE
- WATER REPELLENT COATING
- INTERNAL POCKET
- MESH COVER WITH DRAWSTRING CLOSURE
- EXTREMELY LIGHTWEIGHT



### TECHNICAL FEATURES

Dimensions (LxWxH)	Unit Net Weight	Volume
80x39x37 cm / 31.5"x15.5"x14.5"	0,9 kg / 2 lb	116 L / 7079 cu.in.

## CRUISE X-STRAP

**NEW**

code: 415469

- EASY TO FOLD
- TWO LARGE INTEGRATED POCKETS
- BICOLOR, ULTRALIGHT BUCKLES
- NEOPRENE HANDLES
- ADJUSTABLE, PADDED AND REMOVABLE SHOULDER STRAPS
- AUTO-BLOCKING ZIP
- EXTREMELY LIGHTWEIGHT



### TECHNICAL FEATURES

Dimensions (LxWxH)	Unit Net Weight	Volume
76x31x33 cm / 30"x12"x13"	1,2 kg / 2.6 lb	76 l / 4637 cu.in.

## CRUISE CLASSIC

**NEW**

code: 415473

- HANDLE AND SHOULDER STRAPS
- EXTERNAL FIN POCKET WITH BUCKLE
- ZIP POCKET FOR PERSONAL BELONGINGS
- STURDY AND LIGHTWEIGHT
- REINFORCED BOTTOM



### TECHNICAL FEATURES

Dimensions (LxWxH)	Unit Net Weight	Volume
76x29x36 cm / 30"x11.5"x14"	2 kg / 4.4 lb	79 L / 4821 cu.in.

## CRUISE POOL

**NEW**

code: 415468

- EXTREMELY LIGHTWEIGHT
- EXTERNAL ZIP POCKET
- REINFORCED BOTTOM
- WIDE, LONG STRAP



### TECHNICAL FEATURES

Dimensions (LxWxH)	Unit Net Weight	Volume
69x26x29 cm / 27"x10"x11"	0,7 kg / 1.5 lb	50 L / 3057 cu.in.

## CRUISE BACKPACK MESH DELUXE

**NEW**

code: 415476

- STURDY PVC MESH NET
- ADJUSTABLE SHOULDER AND STERNUM STRAP
- LATERAL ZIP AND STURDY HANDLE
- BOTTOM PROTECTION
- INTERNAL POCKET
- WIDE EXTERNAL POCKET
- BOTTOM EXTENSION WITH DRAINAGE HOLE
- DRAWSTRING CLOSURE



### TECHNICAL FEATURES

Dimensions (LxWxH)	Unit Net Weight	Volume
41x41x75 cm / 16"x16"x29.5"	1,2 kg / 2.6 lb	123,5 L / 7536 cu.in.

## CRUISE BACKPACK MESH ELITE

**NEW**

code: 415477

- CAN BE FOLDED INTO A SMALL BAG WITH HANDLE
- LIGHTWEIGHT
- INTEGRATED SOFT HANDLE
- BOTTOM PROTECTION
- INTERNAL POCKET
- WIDE EXTERNAL POCKET
- BOTTOM EXTENSION WITH DRAINAGE HOLE
- ADJUSTABLE SHOULDER STRAPS



### TECHNICAL FEATURES

Dimensions (LxWxH)	Unit Net Weight	Volume
39x39x74 cm / 15.5"x15.5"x29"	0,5 kg / 1.1 lb	114 L / 6956 cu.in.

## CRUISE JOURNEY

**NEW**

code: 415470

- STYLISH DESIGN
- A NEW CONCEPT FOR DAILY USE, THE OFFICE AND LEISURE
- ADJUSTABLE PADDED SHOULDER STRAPS
- DEDICATED LAPTOP POCKET WITH ZIP
- MULTIUSE ZIPPERED POCKETS
- EXPANDABLE SIDE POCKET
- BICOLOR, ULTRALIGHT BUCKLES
- SHOE COMPARTMENT
- WIDE STRAP TO ALLOW FOR ATTACHMENT TO A TELESCOPIC HANDLE
- CARRYING HANDLE
- ULTRALIGHT MATERIAL
- A.T.O. - AIR TRAVEL OPTIMIZED



### TECHNICAL FEATURES

Dimensions (LxWxH)	Unit Net Weight	Volume
31x20x56 cm / 12.2"x8"x22"	1,2 kg / 2.6 lb	35 L / 2135 cu.in.

## CRUISE BEACH

**NEW**

code: 415506

- ADJUSTABLE SHOULDER STRAP
- CARRY HANDLE
- DOUBLE OUTSIDE POCKETS WITH ZIP CLOSURE
- MESH AREAS FOR A BETTER "AIR-CIRCULATION"
- EXTENDED OPENING FOR EASY ACCESS
- EXTREMELY LIGHT
- IDEAL FOR SNORKELING



### TECHNICAL FEATURES

Dimensions (LxWxH)	Unit Net Weight	Volume
73x27x17cm/28.7x10.6x6.7in	0,43 kg / 0.95 lb	31 L / 1891 cu.in.

## D55

code: 415451

- DRY 55L DUFFLE BAG
- DOUBLE CLOSURE SYSTEM
- LARGE INTERNAL VOLUME
- HAND STRAP & ADJUSTABLE SHOULDER STRAP
- STURDY 500D TARPULIN
- IDEAL FOR WATERSPORTS AND OUTDOOR ACTIVITIES
- SVHC FREE MATERIAL



### TECHNICAL FEATURES

Dimensions (LxWxH)	Unit Net Weight	Volume
60x30x55 cm / 23.5" x 12" x 21.5"	0,9 kg / 2 lb	55 L / 3356 cu.in.

## MBP15

code: 415450

- MODULAR 15L BACKPACK
- ROLL NECK & BUCKLE CLOSURE SYSTEM
- ADJUSTABLE, PRE-SHAPED SHOULDER STRAPS
- PADDED BACKPACK
- ADJUSTABLE CHEST AND WAIST STRAPS
- REMOVABLE LAPTOP AND GADGET SLEEVE
- REMOVABLE MESH POCKET
- STURDY 500D TARPULIN
- IDEAL FOR WATERSPORTS AND OUTDOOR ACTIVITIES
- SVHC FREE MATERIAL



### TECHNICAL FEATURES

Dimensions (LxWxH)	Unit Net Weight	Volume
40x12x65cm / 16" x 5" x 25.5"	1,2 kg / 2.6 lb	15 l / 915 cu.in.

## BP-LIGHT 75 L

code: 415460

- ROLLING CLOSURE SYSTEM
- ADJUSTABLE, PADDED SHOULDER STRAPS
- ADJUSTABLE WAIST STRAPS
- STURDY, LIGHTWEIGHT 210D POLYESTER
- FRONT POCKET WITH WATERPROOF ZIPPER
- IDEAL FOR WATER SPORTS AND OUTDOOR ACTIVITIES
- SVHC FREE MATERIALS



### TECHNICAL FEATURES

Dimensions (LxWxH)	Unit Net Weight	Volume
41x22.5x83 cm / 16.1x8.8x32.6 inch	0,40 kg / 0.89 lb	75 L / 4577 cu.in.

## CRUISE DRY ATTACK TITAN

code : 415524

- HEAT SEALED BAG WITHOUT STITCHING
- 500D TARPULIN, STURDY AND LIGHTWEIGHT
- FOLDABLE WITH A LARGE INTERNAL VOLUME
- ADJUSTABLE HANDLES
- SIDE DRAIN VALVE



### TECHNICAL FEATURES

Dimensions (LxWxH)	Unit Net Weight	Volume
90x46x35 cm / 35.4" x 18.1" x 13.7"	1,7 kg / 3,7lb	144 L / 8787 cu.in

## CRUISE DRY T

**T35**

code: 415452

**T25**

code: 415453

**T10**

code: 415454

**T5**

code: 415455

- DRY BAG TUBULAR AVAILABLE IN FOUR SIZES AND COLORS
- COLOR & SIZE SYSTEM
- ADJUSTABLE SHOULDER STRAP
- QUICK CLOSURE SYSTEM
- STURDY 500D TARPULIN
- IDEAL FOR WATERSPORTS AND OUTDOOR ACTIVITIES
- SVHC FREE MATERIAL



## CRUISE DRY ULTRA LIGHT

**T-LIGHT 25 L**

code: 415461

**T-LIGHT 10 L**

code: 415462

**T-LIGHT 5 L**

code: 415463

- REINFORCED, LIGHTWEIGHT POLYESTER
- QUICK CLOSURE SYSTEM
- HEAT-SEALED STITCHING
- FULLY WATERPROOF
- EXCELLENT FOR WATER SPORTS
- IDEAL FOR OUTDOOR ACTIVITIES
- AVAILABLE IN THREE DIFFERENT SIZES
- SVHC FREE MATERIALS



## CRUISE CARPET

**NEW**

code: 415478

- WATERTIGHT, DOUBLE USE BAG
- DRY CARPET FOR DONNING AND DOFFING DIVE GEAR
- QUICK AND EASY TO FOLD
- DRAWSTRING CLOSURE
- EXTREMELY LIGHTWEIGHT



### TECHNICAL FEATURES

Dimension (D)	Unit Net Weight	Volume
140 cm / 55 inch	0,8 kg / 1,7 lb	75 L / 4577 cu.in.

## CRUISE REG

**NEW**

code: 415471

- ADJUSTABLE SHOULDER STRAP
- INTERNAL ZIPPED MESH POCKET
- VELCRO STRAPS TO ATTACH REGULATORS
- BUSINESS CARD POCKET



### TECHNICAL FEATURES

Dimensions (LxWxH)	Unit Net Weight	Volume
26x10x36 cm / 10"x4"x14"	0,25 kg / 0,55 lb	9,4 L / 573 cu.in.

## CRUISE MESH

code: 415576

- FULL MESH
- TO STORE SCUBA DIVING OR FREE DIVING EQUIPMENT
- CAN BE FOLDED INTO A ROUND BAG WITH HANDLE



## MESH BAG

code: 415515

- PRACTICAL AND COMPACT MESH SACK
- EASY TO CARRY AND FOR RINSING EQUIPMENT
- IDEAL FOR SNORKELING



## CRUISE DIVER

**NEW**

code: 415475

- ADJUSTABLE SHOULDER STRAP
- DEDICATED POCKET FOR COMPUTER AND INTERFACE
- MOBILE PHONE POCKET
- MANY PLACES FOR ELECTRONIC DEVICES
- KEY HOLDER
- CARD HOLDER



## CRUISE PEARL

**NEW**

code: 415474

- VELCRO CLOSURE SYSTEM
- TO STORE AND PROTECT YOUR MASK
- CAN BE ATTACHED TO BELT
- DEDICATED ANTIFOG POCKET



Bag	Cruise Backpack Pro	Cruise Backpack	Cruise Backpack Roller	Cruise Buddy	Cruise Backpack Dry	Cruise Captain	Cruise Quick Pack	Cruise X-strap	Cruise Classic
Code	415464	41565	415466	415467	415540	415472	415598	415469	415473
Dimensions (LxWxH)	47x32x81 cm 18.5"x12.5"x32"	40x31x80 cm 16"x12"x31.5"	47x32x81 cm 18.5"x12.5"x32"	47x32x81 cm 17"x10.5"x29.5"	42x33x79 cm 16.5"x13"x31"	36x22x55 cm 14"x8.5"x22"	80x39x37 cm 31.5"x15.5"x14.5"	76x31x33 cm 30"x12"x13"	76x29x36 cm 30"x11.5"x14"
Unit net weight	5 kg / 11 lb	4,4 kg / 9,7 lb	3 kg / 6,6 lb	3,5 kg / 7,7 lb	1,1 kg / 2,4 lb	2,8 kg / 6,2 lb	0,9 kg / 2 lb	1,2 kg / 2,6 lb	2 kg / 4,4 lb
Volume	128 L / 7811 cu.in.	100 L / 6071 cu.in.	128 L / 7811 cu.in.	87 L / 5309 cu.in.	108 L / 6590 cu.in.	42 L / 2563 cu.in.	116 L / 7079 cu.in.	76 L / 4637 cu.in.	79 L / 4821 cu.in.
A.T.O.	■	■	■	■	■	■		■	■
Air travel optimized	■	■	■	■	■	■			
Heavy duty wheels	■	■	■	■	■	■			
Backpack system	■	■	■		■			■	
Foldable system			■				■		



Bag	Cruise Pool	Cruise Mesh Deluxe	Cruise Mesh Elite	Cruise Journey	Cruise Beach	Cruise Dry Attack Titan	Cruise Carpet	Cruise Reg	Cruise Mesh
Code	415468	415476	415477	415470	415506	415524	415478	415471	415576
Dimensions (LxWxH)	69x26x29 cm 27"x10"x11"	41x41x75 cm 16"x16"x29.5"	39x39x74 cm 15.5"x15.5"x29"	31x20x56 cm 12.2"x8"x22"	73x27x17cm 28.7x10.6x6.7in	90x46x35 cm 35.4"x18.1"x 13.7"	140 cm 55"	26x10x36 cm 10"x4"x14"	95.3x38.1x38.1 cm 37.5"x15"x15"
Unit Net Weight	0,7 kg / 1,5 lb	1,2 kg / 2,6 lb	0,5 kg / 1,1 lb	1,2 kg / 2,6 lb	0,43 kg / 0,95 lb	1,7kg / 3,7lb	0,8 kg / 1,7 lb	0,25 kg / 0,55 lb	0,67 kg / 1,48 lb
Volume	50 L / 3057 cu.in.	123,5 L / 7536 cu.in.	114 L / 6956 cu.in.	35 L / 2135 cu.in.	31 L / 1891 cu.in.	144 L / 8787 cu.in.	75 L / 4577 cu.in.	9,4 L / 573 cu.in.	108,5 L / 6623 cu.in.
A.T.O.	■								
Air travel optimized									
Heavy duty wheels									
Backpack system		■	■	■					
Foldable system			■		■		■		■



Dry Bag	T5	T10	T25	T35	T-LIGHT 5 L	T-LIGHT 10 L	T-LIGHT 25 L	BP-LIGHT 75 L
Code	415455	415454	415453	415452	415463	415462	415461	415460
Polyester Density	-	-	-	-	75	75	210	210
Dimensions (DxH)	16,5x29 cm 6.5x11.4 inch	19,5x33,5 cm 7.7x13.2 inch	25,5x56,5 cm 10.0x22.2 inch	25,5x69 cm 10.0x27.2 inch	15x48 cm 5.9x18.9 inch	20x35 cm 7.8x13.7 inch	24x57,5 cm 9.4x22.6 inch	41x22,5x83 cm 16.1x8.8x32.6 inch
Weight	0,14 kg / 0,31 lb	0,17 kg / 0,38 lb	0,35 kg / 0,77 lb	0,40 kg / 0,89 lb	0,05 kg / 0,11 lb	0,06 kg / 0,13 lb	0,11 kg / 0,24 lb	0,40 kg / 0,89 lb
Volume	5 L / 305 cu.in.	10 L / 610 cu.in.	25 L / 1525 cu.in.	35 L / 2136 cu.in.	5 L / 305 cu.in.	10 L / 610 cu.in.	25 L / 1525 cu.in.	75 L / 4577 cu.in.

\* Dimension (D)

**FORCE PLUS**

code: 415626

- SOFT OVERMOLDED ERGONOMIC HANDLE
- FITS ON MARES BCDS, BAGS AND HOSES
- EASY RELEASE SYSTEM, EVEN WITH GLOVES

**TECHNICAL FEATURES**

<b>Blade</b>	Stainless Steel - PVD Coated
<b>Blade length</b>	100 mm / 3.9 in

**FORCE NANO PLUS**

code: 415627

- SOFT OVERMOLDED ERGONOMIC HANDLE
- FITS ON MARES BCDS, BAGS AND HOSES
- EASY RELEASE SYSTEM, EVEN WITH GLOVES

**TECHNICAL FEATURES**

<b>Blade</b>	Stainless Steel - PVD Coated
<b>Blade length</b>	65 mm / 2.6 in

**COMPACT REEL**

code: 415349

- FOLDABLE HANDLES
- DOUBLE ENDED CARABINER
- 30 m/100 ft LINE

**SAFETY STOP MARKER**

code: 415708

- 3-5 m SAFETY/DECO STOP BUOY
- HIGH VISIBILITY ORANGE COLOR
- LARGE INTERNAL VOLUME
- HD CONSTRUCTION AND STRONG BRASS HOOK

**STANDARD MARKER**

code: 415709

- HIGHLY VISIBLE EGG SHAPE
- ONE PIECE CONSTRUCTION WITH INTEGRATED FLAG
- TWO-CHAMBER CONSTRUCTION FOR SAFETY AND AN UPRIGHT POSITION
- 20 m ROPE
- VARIOUS HOOKS

**TORPEDO**

code: 415721

- LOW-DRAG TORPEDO SHAPE FOR EASY TOWING
- HIGH VISIBILITY ORANGE COLOR
- TWO-CHAMBER CONSTRUCTION FOR SAFETY AND AN UPRIGHT POSITION
- 20 m ROPE
- SIX UNIVERSAL ADJUSTMENT CONNECTORS

**DIVER MARKER BUOY - ALL IN ONE**

code: 415753

- 180 cm HEIGHT
- 5 cm/2" SOLAS REFLECTIVE TAPE
- EXTREMELY LIGHTWEIGHT
- "DIVER BELOW" REFLECTIVE WRITING
- INTEGRATED MESH POCKET FOR SPOOL
- 20 m/66 ft SPOOL INCLUDED
- STAINLESS STEEL D-RING
- DOUBLE ENDER STAINLESS STEEL CARABINER
- ORAL INFLATE CONNECTOR FOR LP BCD HOSE
- OVER PRESSURE RELEASE VALVE
- VELCRO CLOSURE SYSTEM

**DIVER'S ALERT MARKER**

code: 415743

- 180 cm TALL AND 15 cm WIDE FOR HIGH VISIBILITY
- SOLAR REFLECTIVE TAPE
- AUTOMATIC SEAL SYSTEM
- ORAL INFLATION CONNECTOR FOR LP BCD HOSE
- PRESSURE RELEASE VALVE
- DEDICATED POCKET FOR LIGHT
- STAINLESS STEEL DRING

**COMPACT**

code: 415742

- ORANGE DIVER MARKER BUOY
- 10 m LINE
- 300g-2/3lbs SHAPED LEAD WEIGHT
- NYLON SACK WITH CARABINER

**STANDARD INFLATABLE**

code: 415707

- HIGH VISIBILITY ORANGE COLOR
- FOLDING BAG WITH HOOK
- 20 m ROPE AND VARIOUS HOOKS
- INTEGRATED WEIGHTS FOR PROPER SURFACE FLOTATION
- FITS IN BCD POCKET



**UNIVERSAL HANGER**

code: 415177

- HOLDS UP TO 15 DIFFERENT ITEMS
- UNIQUE MARES DESIGN
- STURDY AND ROBUST
- EQUIPMENT PERFECTLY ORGANIZED

**DRYSUIT HANGER**

code: 415713

- PERFECT FOR DRY SUITS WITH BOOTS
- BETTER VENTILATION BECAUSE THE DRY SUIT IS UPSIDE DOWN
- STURDY AND SIMPLE TO USE

**WEIGHT BELT**

code: 415122

- QUICK RELEASE PLASTIC BUCKLE

**STAINLESS STEEL BELT**

code: 415123

- QUICK RELEASE STAINLESS STEEL BUCKLE

**LIQUID PATCH**

code: 415181 BK

code: 415181 GR

- IDEAL FOR REPAIRING HOLES AND SMALL CUTS
- CAN BE USED ON NEOPRENE, BC VESTS, DRY SUITS AND MORE
- AVAILABLE IN BLACK AND GREY
- EASY TO USE, JUST THREE STEPS
- FLEXIBLE AND ELASTIC
- 20 gr

**SILICONE GREASE**

code: 415102

- IDEAL FOR MAINTENANCE AND TO LUBRICATE O-RINGS
- MADE IN COMPLIANCE WITH LATEST REGULATIONS
- 20 ml

**SCUBA CLEAN**

code: 415905 - Desk Exhibitor (12pcs)

- MARES SANITIZER FOR ALL SCUBA GEAR
- TRIPLE ACTION: FUNGICIDE, BACTERICIDE AND VIRUCIDE
- OFFERS TOTAL DISINFECTION, CLEANLINESS AND SANITIZATION
- COMPATIBLE WITH PLASTIC, NYLON, NEOPRENE AND METAL
- 125 ml

**SNORKELING VEST**

code: 417750

- ONE SIZE FITS ALL
- SECURE AND COMFORTABLE SURFACE FLOTATION
- ADJUSTABLE ABDOMINAL STRAP
- QUICK-RELEASE BUCKLE
- EASILY ACCESSIBLE ORAL INFLATOR

**SHELLS**

- SHOCKPROOF CASE
- STURDY ZIPPER
- MARES MICRO-INJECTED LABEL
- SILVER PIPING

**SHELL REGULATOR**

code: 415866

- PERFECT SIZE FOR STORING REGULATORS
- DEDICATED HANDLE FOR EASY CARRYING

**SHELL OVAL**

code: 415864

- PERFECT FOR TORCHES, MASKS AND MORE

**SHELL ROUND**

code: 415865

- IDEAL FOR DIVE COMPUTERS

**DIVING BOX**

code: 415516

- TO STORE, PROTECT AND CARRY DIVING EQUIPMENT
- SIZES: 82x42x38cm
- REMOVABLE HANDLE
- RELIABLE WHEELS
- STURDY MATERIAL

**PERSONAL DRY BOX**

code: 415727

- LANYARD FOR TRANSPORTATION
- DRY SEAL FOR WATERTIGHT CLOSURE
- SLEEK DESIGN
- SMALL AND DURABLE

**MAGNETIC SHAKER**

code: 415172

- SPECIAL MAGNETIC SYSTEM
- TO PREVENT UNWANTED AND IRRITATING NOISE
- LIGHTWEIGHT AND EASY TO STORE
- EASY TO USE WITH JUST A SIMPLE DOWNWARD MOVEMENT

**AIR NOZZLE**

code: 415724

- EASY TO USE
- QUICK CONNECTION AND DISCONNECTION FROM LP INFLATOR HOSE
- USE AIR TO CLEAN AND DRY
- NOT ONLY FOR SCUBA EQUIPMENT

**UNDERWATER SLATE**

code: 415719

- BRIGHT WHITE WRITING SLATE
- COMPACT SIZE: 12X15 cm
- HOOK SYSTEM TO ATTACH TO YOUR BCD
- QUICK RELEASE BUCKLE
- STANDARD REPLACEABLE PENCIL WITH SILICONE TUBE



**TANKS**

- code 10L Single Valve: **415081**
- code 12L Single Valve: **415082**
- code 15L Double Valve: **415083**

- SINGLE PIECE CONSTRUCTION IN STEEL ALLOY
- 3 SIZES: 10L, 12L AND 15L
- MEETS REQUIREMENTS OF DIRECTIVE 2014/68/EU
- INT/DIN VALVE CONNECTION
- RUBBER BOOT
- OPTIONAL SECOND CONNECTION FOR 10L AND 12L SINGLE VALVE



**TANK NETS**

- code 10L YL: **415749**
- code 12L BL: **415731**
- code 15L BK: **415730**

- HIGH QUALITY NYLON
- VARIOUS COLORS & SIZES
- 10L/YELLOW, 12L/BLUE AND 15L/BLACK



**VALVE 2ND CONNECTION**

- code: **45180732**

- INT/DIN VALVE CONNECTION
- OPTIONAL FOR 10 AND 12 LITER TANK VALVES



Single piece construction in steel alloy with chrome molybdenum 3CrMo4 (DIN 17200).

Code	415081	415082	415083
Volume	10 liters	12 liters	15 liters
Valve	single	single	double
Weight	13.5 kg / 29.6 lb	16.5 kg / 36.5 lb	20 kg / 44.1 lb
Height	67 cm / 26.4 in	61 cm / 24.0 in	71 cm / 28.0 in
Diameter	18 cm / 7.0 in	22 cm / 8.6 in	22 cm / 8.6 in
Operating pressure	232 bar		
Material	heat-treated steel		
Internal coating	phosphate coating and anti-corrosion treatment		
Black external coating	soft touch polyurethane coating		

**DIVER TOOLKIT**

- code: **415726**

- IDEAL FOR TROUBLE-SHOOTING ON DIVING EQUIPMENT
- 20 TOOLS INCLUDING SPANNERS, SCREWDRIVERS, PLIERS, ALLEN KEYS AND MORE
- HANDY SIZE ZIPPERED CASE
- EASY STORAGE



**MULTI TOOLS**

- code: **415701 Multi Tools Pro**
- code: **415703 Multi Tools Tech**

- TWO VERSIONS FOR ALL NEEDS
- TECH: VARIOUS SPANNERS AND SCREWDRIVERS
- PRO: VARIOUS SPANNERS AND ALLEN WRENCHES
- HIGH QUALITY STAINLESS STEEL WITH NICKEL COATING
- EASY TO USE
- EXCLUSIVE MARES DESIGN
- OVERMOLDED HANDLE WITH MARES LOGO



**JACKET**

- code: **449127**



**TECHNICAL FEATURES**

	Unisex
Size	XS · S · M · L · XL · XXL
Characteristics	Waterproof / Refolding hood

**HOODED SWEATER**

- code: **449129**



**TECHNICAL FEATURES**

	Unisex
Size	XS · S · M · L · XL · XXL
Characteristics	100% cotton

**POLO**

- code: **449130**



**TECHNICAL FEATURES**

	Unisex
Size	XS · S · M · L · XL · XXL
Characteristics	100% cotton

**T-SHIRT**

- code: **449128**



**TECHNICAL FEATURES**

	Unisex
Size	XS · S · M · L · XL · XXL
Characteristics	100% cotton



### POP TORCHES

code: 449667

- PLEXIGLAS DESK DISPLAY
- EOS RZ TORCH RANGE
- SIZE: APPROX 35 X 60 cm



### POP AST

code: 449662

- CARDBOARD DESK DISPLAY
- SIZE: 22 X 30 cm



### POP QUAD AIR

code: 449666

- CARDBOARD TOWER DISPLAY
- SIZE: APPROX 55 X 125 cm



### POP LOOP

code: 449656

- SIZE: APPROX 65X170 cm



### POP BUNGEE STRAP

code: 449664

- CARDBOARD DESK DISPLAY
- SIZE: 22 X 30 cm



### POP EPIC 82X

code: 449665

- CARDBOARD TOWER DISPLAY
- SIZE: APPROX 55 X 125 cm



### POP DISPLAY

#### FRAME

code: 449643

- SIZE: 50X180 cm
- FRAME ONLY

#### REGULATORS KIT SUPPORT

code: 449647

- 6 REGULATOR SUPPORTS
- ALSO FITS STANDARD SLATWALLS

#### INSTRUMENTS KIT SUPPORT

code: 449644

- 3 WRIST COMPUTER BARS + 1 CONSOLE SUPPORT
- ALSO FITS STANDARD SLATWALLS



### POP DRY BAGS

code: 449659

- CARDBOARD DISPLAY
- SIZE: APPROX 80X200 cm



## REGULATORS

#### DFC - DYNAMIC FLOW CONTROL:

Minimizes intermediate pressure drop during inhalation thus maximizing gas delivery, especially under extreme conditions.

#### AST - AUTO SEALING TECHNOLOGY:

Pneumatic dry system, protects against water entering the 1<sup>st</sup> stage.

#### NCC - NATURAL CONVECTION CHANNEL:

Increases cold water performance by creating a flow of water across the regulator. The flow is driven by the change of density in water with temperature.

#### OPD - OPTIMIZED PORT DESIGN:

Ensures that the pressure gauge's hose is always pointing downwards, regardless of first stage orientation.

#### TWIN POWER SYSTEM:

Flow control manages the delivery rate of your gas, from natural breathing to power breathing. The former is the traditional way of breathing a Mares regulator, (VAD) while the latter (VAD+) provides an extra push when you need it.

#### VAD - VORTEX ASSISTED DESIGN:

The air bypass tube delivers air to the mouthpiece creating a swirling vortex with a low pressure area in the center that keeps the diaphragm down during inhalation, for very sensitive and easy breathing at all depths.

#### ADJUSTABLE BREATHING COMFORT:

Allows the diver to change the second stage spring load which affects the breathing resistance.

#### PAD - PNEUMATICALLY ASSISTED DESIGN:

The second stage is accomplished by routing medium pressure air to the backside of the valve to help counteract the force of the spring. This allows the valve to open with less effort.

#### MESH GRID:

Patented design which reduces the impact of water flow onto the second stage diaphragm, thus eliminating free flows even in strong currents.

#### METAL TECHNOLOGY:

Outstanding mechanical reliability and high thermal conductivity make our metal 2nd stages extremely long lasting and ideal for cold water dives. The high thermal conductivity of metal reduces also the dry mouth feeling during the dive.

#### FLUID DYNAMIC DEFLECTOR:

Receives and properly directs the airflow from the bypass tube to the mouthpiece.

#### SUPERFLEX LP HOSE:

Extreme light weight and exceptional softness guarantee the maximum freedom of movement.

## INSTRUMENTS

#### LCD COLOR DISPLAY:

State-of-the-art smartphone technology applied to dive computers (320 x 240 pixels / 262.144 colors).

#### FULL DOT MATRIX:

The next generation of dive computer displays: exceptional resolution allowing for total flexibility. The best user interface, the best dive display, no compromises.

#### SEGMENT / MATRIX AREA DISPLAY:

The perfect compromise between sharpness (segments) and flexibility (dot matrix) at a reasonable price.

#### SEGMENT DISPLAY:

Needle-sharp information combined and intelligent placement of information for easiest readability.

#### GAS INTEGRATED:

Provides all relevant gas related information such as tank pressure, time to reserve, and gas consumption resulting in a significant increase in safety.

#### GAS SWITCHING:

Setting the computer to include one or more oxygen enriched - gases (up to 99%) in addition to your main gas; allow you to benefit from shorter decompression times by switching gases during the dive.

#### MINERAL GLASS (TEMPERED):

Superior scratch resistance and improved readability in all diving conditions and viewing angles.

## BCD'S

#### FUSION BLADDER:

Combines features of backmounted and classic bladder. High lift capacity, unrestricted movement and a comfortable position on the surface characterize this type of bladder.

#### BACKMOUNTED:

Aircell separated from the harness, resulting in unrestricted freedom of movement.

#### ERGO INFLATOR:

The standard inflation and deflation control device used in sanctioned training programs. Intuitive use and secure grip.

#### AIRTRIM:

Patented technology for easiest and precise buoyancy control in all positions and conditions. The control device is always at hand and placed in the most ergonomic position.

#### MONOPLATE BACKPACK:

Ideal for travelling thanks to its reduced dimensions and its marked weight reduction compared to a traditional backpack. Integrated rubber pads provide secure grip of the tank and carrying comfort.

#### SUSPENSION SYSTEM:

Inspired by the design of modern hiking backpacks, the system avoids direct contact between body and tank support.

## SUITS

#### ULTRASTRETCH NEOPRENE:

Top of the range neoprene which delivers superior comfort during diving as well as when donning and doffing.

#### BACK PROTECTION SYSTEM:

Ergonomically shaped neoprene cushion between back and tank support for improved wearing comfort and extra warmth in a zone which is usually cold sensitive.

#### G-LOCK ZIPPER:

Soft, flexible waterproof zip ensures maximum freedom of movement and optimum thermal comfort.

#### S-LOCK ZIPPER:

Soft, flexible waterproof zip ensures maximum freedom of movement. Thermal comfort is increased by the zip coating which limits water entry.

#### MASTERSEAL ZIP:

Extremely sturdy and durable dry zipper. The new soft and flexible Masterseal zip ensures maximum freedom of movement and optimum thermal protection.

#### DOUBLE CONE:

The Double Cone System minimize the water flow in the most critical sealing areas like wrist and ankles.

#### THERMO PLUSH:

Extremely soft internal layer in the chest area to keep the upper part of the body warm. Thermo plush is durable and dries fast.

## FINS

#### RIDDLED FOOT POCKET:

The perforations prevent stagnating water flow from slowing you down. Eliminating this "parachute effect" you'll slide faster through the water. Furthermore the openings eliminate any suction effect, making doffing easier.

#### OPB - OPTIMIZED PIVOTING BLADE:

Allows the blade to maintain an optimal angle throughout the kicking cycle, whereas traditional fins achieve this only during a small portion of the cycle. OPB produces a constant thrust, which minimizes fatigue and produces fluid movement through the water.

#### CHANNEL THRUST:

Soft longitudinal inserts allow a controlled deformation of the fin blade while kicking. This channel shape moves a greater amount of water resulting in more thrust for the same effort.

#### TRI-MATERIAL CONSTRUCTION:

3 specific materials for maximum elasticity, high durability and resistance to aging. The result is superior performance in all diving conditions.

## MASKS & SNORKELS

#### LIQUIDSKIN:

Patented Technology. The exclusive Bi-Silicone technology uses two different types of silicone: a firmer portion for support structure and a softer portion for contact with your face. It is 45% softer for unparalleled comfort and 270% more elastic for a perfect fit.

#### SUNRISE:

The Sunrise masks are dedicated to the Asian market and wider faces because of the special geometry of the skirt.

#### TRI-COMFORT:

Small horizontal ribs between the frame and the skirt in the area around the nose. These ribs absorb and redistribute the pressure exerted by the frame onto the skirt, with a resulting increase in comfort.

#### OPTICAL LENSES:

Mares offers corrective lenses for most models. In addition to the negative diopters, for some models also positive diopters are available. Mares design makes it quick and easy to install lenses.

## ACCESSORIES

#### LIGHTS

##### MAGNETIC SWITCH:

The external magnetic switch protects the light from flooding. High reliability ensured by the complete absence of o-ring.

##### ADJUSTABLE FOCUS:

The focus can be adjusted during the dive by a simple rotation. It allows for a change in the light beam between 12° and 75°.

##### IN-HOUSE RECHARGEABLE BATTERY:

Rechargeable batteries are standard. The system allows recharging without removing the batteries from the flashlight.

#### BAGS

##### ATO - AIR TRAVEL OPTIMIZED:

The choice of extremely lightweight and resilient materials, in addition to the overall attention to details, make these products ideal for the travelling diver.

##### HEAVY DUTY WHEELS:

All Mares bags include rugged and durable construction wheels, secured with stainless steel screws.

##### BACKPACK SYSTEM:

Ergonomically designed shoulder straps are included and stored in an appropriate pocket.

##### FOLDABLE SYSTEM:

The product can be folded into itself in less than one minute to store it in small space.

# SEMINARS 2019



## THE MARES LAB SERVICE TECHNICIAN TRAINING PROGRAM

Mares Service Technician Training Courses are available throughout the world and are designed and developed based on proven effective instructional system design principals. They are the dive industry's first and only competency based service technician training courses offered worldwide that are produced and conducted by a major dive equipment manufacturer. This means you'll receive the same high quality and educationally valid training regardless of where in the world you participate in a Mares Service Technician Training Course.

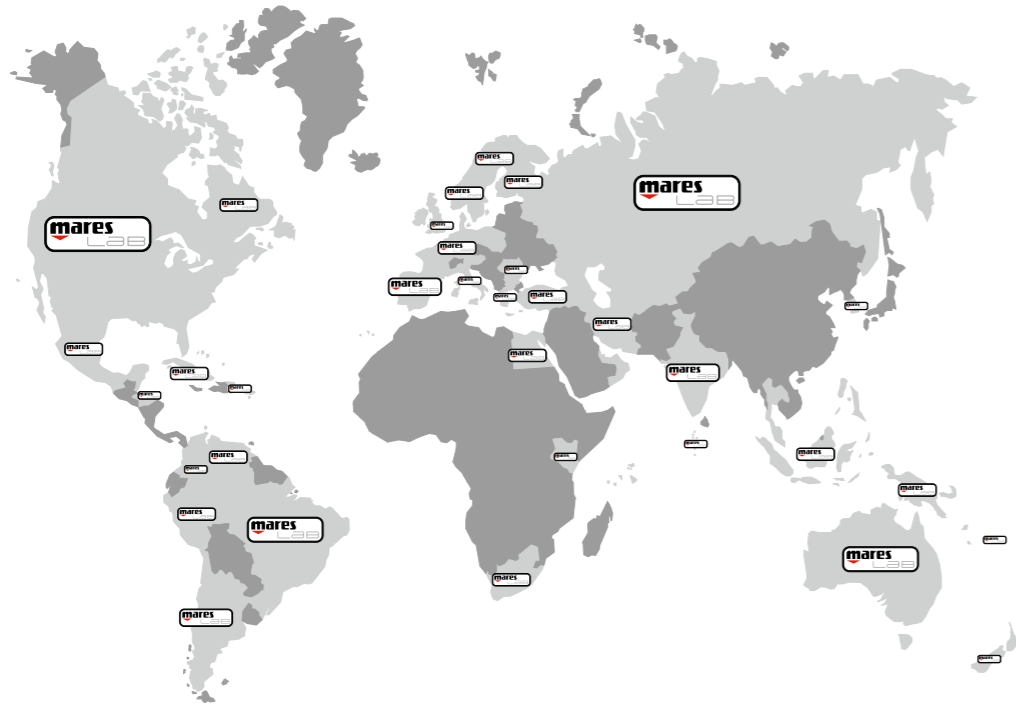

### BASIC SERVICE TECHNICIAN DIGITAL LEARNING COURSE

This highly interactive online digital learning course is delivered to the learner using the latest Educational Management System (EMS) technology. The EMS platform technology along with extensive use of video and graphic content enhances learning and retention of information and produces a highly enjoyable educational experience. The course is open to anyone, and can be accessed by contacting the local Mares Subsidiary or Distributor. Take this course as the first step to becoming a fully qualified Mares Service Technician, or if you simply want to learn the basics of regulator design and service and/or repair. This course is a prerequisite requirement for most Mares Lab Skill Based Training Courses. Completion of this course does not qualify you to service or repair Mares equipment.



- The course goals are to:
1. Establish your basic knowledge level relating to regulator service and repair procedures.
  2. Provide you with basic information about regulator design and function.
  3. Provide you with Mares specific information relating to service and repair procedures, manufacturing processes and product information.
  4. Help prepare you for success in one or more Mares Lab Skill Based Training Courses.

**Prerequisite Requirements:**  
Course is open to anyone.

### MARES LAB SKILL BASED TRAINING COURSES

- MARES SERVICE TECHNICIAN
- MARES DIVING CENTER SERVICE TECHNICIAN
- MARES SPECIALTY SERVICE TECHNICIAN



After successfully completing the Basic Service Technician Digital Learning Course, you are now ready to progress to the skill based training phase of becoming a qualified Mares Service Technician. These courses are conducted by qualified Mares Lab Instructors and consist of comprehensive hands-on training exercises. During these courses you will have the opportunity to perform multiple service procedures on a wide variety of Mares products, including multiple complete regulator service overhauls on various Mares regulators. You'll also gain valuable experience in using the Mares Service Manual and Spare Parts Catalog during routine and special service procedures. Skill based training courses are designed to:

1. Provide comprehensive, real world, hands-on training about how to service and repair Mares products.
2. Enhance the knowledge gained from the Basic Service Technician Digital Learning Course.
3. Develop skills and abilities to the level required to successfully perform service and repair procedures on Mares products.
4. Prepare you for a successful full or part-time career as a Mares Service Technician.

# SEMINARS 2019



### • MARES SERVICE TECHNICIAN

This is by far the most popular of the skill based training courses. The all new and redesigned Mares Service Technician Training Course is a comprehensive 2 day training program that trains and qualifies individuals to service and repair Mares products. Topics include disassembly, reassembly and adjustment of in-line Mares regulators, service and repair procedures, troubleshooting, dive computers, Mares warranty, service guidelines and more. More than 12 hours of course time is dedicated to hands-on, skill based training on how to properly disassemble, reassemble and adjust Mares regulators and BC inflator mechanisms. **Successful completion of this course qualifies you to service and/or repair ALL Mares products.**

**Prerequisite Requirements:**

Completion of the Basic Service Technician Digital Learning Course.  
Be currently affiliated with an Authorized Mares Dealer.  
Be approved by the affiliated Mares Dealer to attend the course.

### • MARES DIVING CENTER SERVICE TECHNICIAN

This course is designed for technicians who plan to work in a Mares Diving Center, such as a resort or diver training facility, that has limited or no retail sale of Mares equipment. Course duration is 1 day and provides skill based training related to the Mares Diving Center product line. Take this course if you plan to work in a Mares Diving Center and are interested in being able to service and repair your affiliated Mares Diving Center owned Mares products. **Successful completion of the Diving Center Service Technician Course qualifies you to service and repair ONLY your affiliated Diving Center OWNED equipment used in rental and/or training programs.**

**Prerequisite Requirements:**

Completion of the Basic Service Technician Digital Learning Course.  
Be affiliated with an Authorized Mares Diving Center.  
Be approved by the affiliated Mares Diving Center to attend the course.

### • MARES SPECIALTY SERVICE TECHNICIAN

These courses are designed to train technicians to service and repair specific Mares products. Specialty Service Technician Training Course duration is approximately 1 day, depending on the course requirements and the number of products included in the course. **Successful completion of this course qualifies you to service and/or repair ONLY the specific Mares products for which you were trained.** These products will be listed on your qualification certificate. Contact your local Mares Subsidiary or Distributor for additional information on Specialty Service Technician Training Courses available in your area.

**Prerequisite Requirements:**

This varies according to the specific Specialty Service Technician Training Course requirements.  
Authorization by a current Mares Dive Center or Mares Dealer.

### • MARES SERVICE TECHNICIAN UPDATE

In order to maintain your Mares Service Technician qualification, you must attend the Annual Renewal Seminar within one (1) year\* of completing a Service Technician Training Course or Annual Renewal Seminar. Annual Renewal Seminar is available online and/or as instructor led Update Seminars and are conducted regularly throughout the year, providing you with numerous opportunities to maintain your Mares qualification.

Update Seminar topics typically include new products, new and updated service procedures and a review of current Service Bulletins.  
\* Within one (1) year is defined as December 31st of the year in which the one year limit is reached.

**Prerequisite Requirements:**

Currently qualified as a Mares Lab Service Technician.  
Qualification date is within the one (1) year update requirement.

### THE MARES LAB TRAINING CYCLE®

The Mares Lab Training Cycle is a process that has proven effective in producing what we call "best in class results". This means that as a qualified Mares Service Technician, you can be confident that you've successfully completed the dive industry's most comprehensive dive equipment service and repair training program available through a dive equipment manufacturer. You can also be proud of the fact that you earned your qualification by demonstrating a "best in class" level of dive equipment service technician skills and abilities. Here's how the Mares Lab Training Cycle works:

**Your Knowledge Development**

Your basic dive equipment service and repair knowledge is established during your digital learning course and further enhanced during your skill based training course.

**Your Skill Development**

Your service and repair skills are enhanced during your skill based training course through a series of hands-on training exercises. Over 90% of the contact hours in these courses are dedicated to skill development.



**Your Abilities Confirmed**

Your knowledge and skill levels achieved through the Mares Lab training process are objectively evaluated and must meet the minimum core competency requirements in order to be qualified as a Mares Service Technician.

**Your Abilities Improved**

Your abilities improve over time by gaining additional knowledge and increasing skill levels. This is achieved through experience as a Mares Service Technician, by regular contact and communication with Mares Technical Assistance staff, by receiving periodic product updates and Service Bulletins and by participating in Service Technician Update Seminars.

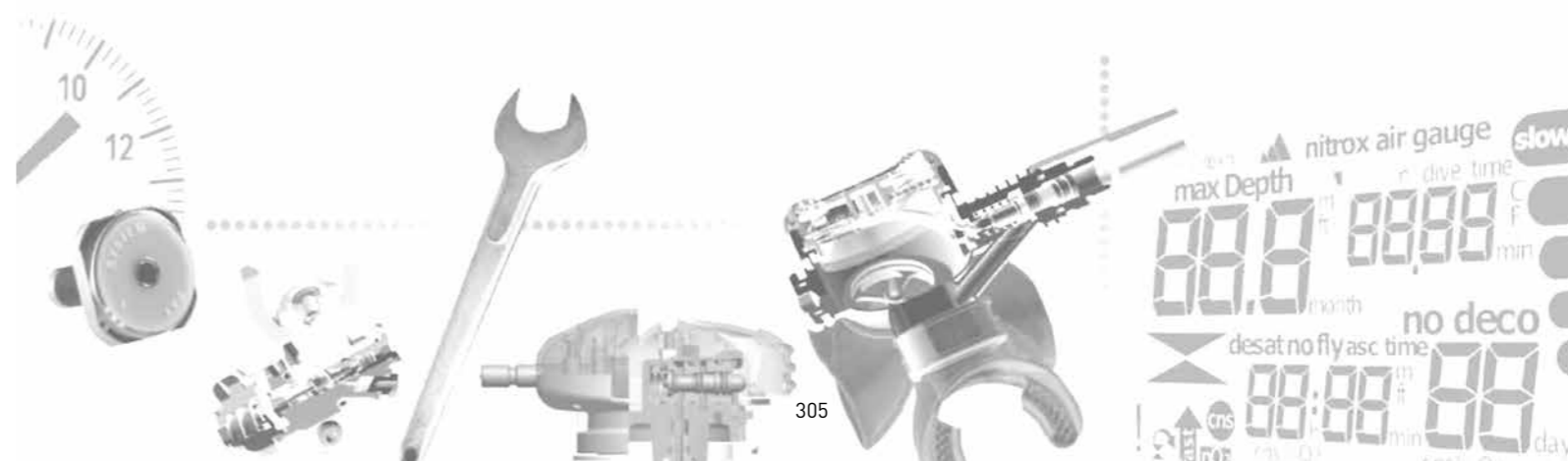

Product specifications and characteristics listed in this catalogue may be subject to changes by Mares without notice.

The trademark **mares**® is a registered trademark.

**ISO 9001:2015 certified**

**mares**



**Mares S.p.A.**  
Salita Bonsen 4  
P.O. Box 142  
16035 Rapallo (Genova) · ITALY  
Tel. +39 0185 2011 / fax +39 0185 201470  
[www.mares.com](http://www.mares.com)